



## PNEUMATIC C-RING TOOL SC7 SC7C

### SAFETY INSTRUCTIONS

#### WARNINGS

- **Always** read tool manual before operating.
- Always wear safety glasses while operating or while in the vicinity of a tool in operation.
- For testing, always cycle tool away from work to insure proper ring closure. For safety reasons, an improperly functioning tool **must not** be used. When operating tool, never point or actuate tool other than into work.
- Operate tool in an unobstructed work area.
- Disconnect air supply prior to maintenance and/or repair of tool.
- Use clean dry air to maximize efficiency. **Do Not Exceed 100 P.S.I. (7.0 kg/cm sq.)**
- Do not use bottled gases such as oxygen, hydrogen, carbon dioxide, acetylene, etc.
- Tools shall be operated with a fitting or hose coupling on or near the tool in such a manner that all compressed air in the tool is discharged at the time the fitting or hose coupling is disconnected.



#### WARNING:

The employer and/or user must ensure that proper eye protection is worn. Eye protection equipment must conform to the requirements of the American National Standard Institute, ANSI Z87.1-1989 and provide frontal and side protection. Eye protection should be worn by the operator and others in the work area when loading, operating, or servicing this tool. Eye protection is required to guard against possible flying particles and/or debris, which could cause severe eye injury.

NOTE: Non-side shielded prescription glasses and faceshields alone do not provide adequate protection.

#### OPERATION

##### **▲WARNING:**

Always handle tool with care:

- Never engage in horseplay.
- Never pull the trigger unless nose of tool is directed toward the work.
- Keep others at a safe distance from the tool while the tool is in operation as actuation occurs, possibly causing injury. Keep hands and body away from the jaw mechanism of the tool.

#### LOADING TOOL

##### **▲WARNING:**

When loading tool:

- Never place a hand or any part of body in jaw mechanism area of tool.
- Never point tool at anyone.
- Never actuate tool when loading, accidental injury may occur.

#### AIR CONSUMPTION

SC7 Series Tools require 3.3 cubic feet per minute (.093 cubic meters per minute) of free air to operate at a rate of 100 fasteners per minute, at 100 P.S.I. (7.0 kg/cm sq.).

# STANLEY®

# Fastening Systems

SC7  
SC7C

ITEM	DESCRIPTION	PART NUMBER	QUANTITY	
1	SCREW, #10-24 X 1" BUTTON HD. CAP	TL770216	4	4
2	CAP, END	B04582	1	1
3	GASKET	B04583	1	1
4	"O" RING	SC10	1	1
5	PISTON	B04580	1	1
6	BUSHING, PISTON ROD	SC102	1	1
7	"O" RING	SC08	5	5
8	SCREW, SET	SC23	2	2
9	PLUG, MANIFOLD 1/8-27	1753	1	1
10	ROLL PIN	SC05	3	3
11	ROD, PISTON	B04581	1	0
		B04578	0	1
12	ROLLER	B01440	4	0
		B01854	0	4
13	PIN, ROLLER	SC01	2	2
14	BLADE, FEEDER	B01503F	1	0
		B01689F	0	1
15	SIDE PLATE (R & L)	B04584F	2	2
16	NUT, NYLOCK	SC77	2	2
17	SPRING, LATCH	B01438F	1	1
18	WASHER, JAW BOLT	B01442	2	2
19	NUT, NYLOCK	SC13	2	2
20	LATCH	C01845F	1	1
21	JAW, UPPER	C01852F	1	0
		C01855F	0	1
22	BUSHING, JAW	B01441	2	2
23	JAW, LOWER	C01853F	1	0
		C01856F	0	1
24	GUARD, TRIGGER	B01435F	1	1
25	TRIGGER	A02073F	1	1
26	ROLL PIN	TR105026	3	3
27	PUSHER, 3/4" RING	C04573	1	1
28	SCREW, #10-24 X 1/4" BUTTON HD. CAP	TL770204	3	3
29	SHOE, MAGAZINE	B04545	1	1
30	SHIM, MAGAZINE (.010")	B1545010	A/R	A/R
	SHIM, MAGAZINE (.005")	B1545005		
31	MAGAZINE BODY (PLASTIC)	D04568	1	1
32	SCREW, #6-19x1/4" PAN HD.	TL846206	3	3
33	GUARD, 3/4" RING	B04571	1	1
34	BOLT, JAW	B01507	2	2
35	SPRING, CONSTANT FORCE	SC97A	1	1
36	CLIP, ANTI-BACKUP	B04570	1	1
37	ROLL PIN 3/32" X 11/16"	TL861511	2	2
38	BRACKET, SPRING SPOOL	C04574	1	1
39	SPRING, SHOE	SC100	2	2
40	RAIL, SC7 FEEDER GUIDE	B04575	1	1
41	SCREW, #10-24 X 1" SOCKET HD. CAP	TL710216	2	2
42	SCREW, BUTTON HD. CAP	SC18	1	1
43	STEM, THROTTLE	B01425F	1	1
44	SEAT, FRONT VALVE	B03042	1	1
45	"O" RING	SC09	2	2
46	SCREW, VALVE SOCKET HD. CAP	SC21	2	2
47	HOUSING, MACHINED	D04579F	1	1
48	GRIP	C03916	1	1
49	SPACER, THROTTLE VALVE	B03044	1	1
50	SPRING, VALVE	B04587	1	1
51	SEAT, REAR VALVE	B03043	1	1
52	DEFLECTOR, AIR	B01426	1	1
53	SUPPORT, O-RING END	B01421	4	4
54	SUPPORT, O-RING CENTER	B01422	2	2
55	WASHER, THROTTLE VALVE	B01455	2	2

\* "A/R" DENOTES AS REQUIRED FOR OPTIMUM PERFORMANCE

ASSEMBLIES	
DESCRIPTION	ITEMS INCLUDED
CYLINDER HOUSING COMPLETE AD04579F	6, 7, 9, 48, 49
MAGAZINE COMPLETE AD04568	26, 29, 31, 32, 33, 36, 40
SPRING SPOOL BRECKET ASSEMBLY AC04574	35, 37, 38
PUSHER ASSEMBLY COMPLETE AB04575	AC04574, 26, 27, 28, 37, 40

## RECOMMENDED SPARE PARTS LIST

ITEM	DESCRIPTION	PART NUMBER	NO. OF TOOLS		
			1	5	10
1	SCREW, #10-24 X 1" BUTTON HD. CAP	TL770216	2	4	8
3	GASKET	B04583	1	2	4
4	"O" RING	SC10	1	2	4
5	PISTON	B04580	0	1	2
6	BUSHING, PISTON ROD	SC102	0	1	2
7	"O" RING	SC08	5	10	20
8	SCREW, SET	SC23	1	2	4
10	ROLL PIN	SC05	1	2	3
11	ROD, PISTON	B04581	0	0	1
		B04578			
12	ROLLER	B01440	4	8	16
		B01854			
13	PIN, ROLLER	SC01	2	4	8
14	BLADE, FEEDER	B01503F	1	2	3
		B01689F			
16	NUT, NYLOCK	SC77	2	4	6
17	SPRING, LATCH	B01438F	1	2	4
18	WASHER, JAW BOLT	B01442	2	4	8
19	NUT, NYLOCK	SC13	2	4	8
20	LATCH	C01845F	1	2	3
21	JAW, UPPER	C01852F	1	2	3
		C01855F			
22	BUSHING, JAW	B01441	2	4	6
23	JAW, LOWER	C01853F	1	2	3
		C01856F			
25	TRIGGER	A02073F	1	2	3
26	ROLL PIN	TR105026	2	4	6
27	PUSHER, 3/4" RING	C04573	0	1	2
28	SCREW, #10-24 X 1/4" BUTTON HD. CAP	TL770204	2	4	8
29	SHOE, MAGAZINE	B04545	0	1	2
30	SHIM, MAGAZINE (.010")	B1545010	2	8	12
	SHIM, MAGAZINE (.005")	B1545005	1	4	6
31	MAGAZINE, ASSEMBLY	AD04568	0	1	2
32	SCREW, #6-19x1/4" PAN HD.	TL846206	1	2	4
33	GUARD, 3/4" RING	B04571	0	1	2
34	BOLT, JAW	B01507	1	2	4
35	SPRING, CONSTANT FORCE	SC97A	1	2	4
36	CLIP, ANTI-BACKUP	B04570	1	2	3
37	ROLL PIN 3/32" X 11/16"	TL861511	1	2	4
39	SPRING, SHOE	SC100	2	4	6
40	RAIL, SC7 FEEDER GUIDE	B04575	0	1	2
41	SCREW, #10-24 X 1" SOCKET HD. CAP	TL710216	2	2	4
42	SCREW, BUTTON HD. CAP	SC18	1	2	3
44	STEM, VALVE	B01425F	0	1	2
45	"O" RING	SC09	2	4	6
46	SCREW, VALVE SOCKET HD. CAP	SC21	1	2	3
47	HOUSING, ASSEMBLY	AD04579F	0	0	1
50	SPRING, VALVE	B04587	1	2	3
53	SUPPORT, O-RING END	B01421	2	2	4
54	SUPPORT, O-RING CENTER	B01422	1	1	2
55	WASHER, THROTTLE VALVE	B01455	1	1	2

## RECOMMENDED TOOL LIST

DESCRIPTION	
3/16"	75° Angle Head Wrench
5/16"	Combination Wrench
3/8"	Combination Wrench
7/16"	Combination Wrench
1/2"	Combination Wrench
9/16"	Combination Wrench
Long Hex. Key Set (Sizes: 1/16, 1/8, 9/64, 5/32, 3/16)	
T15 Torx Driver	
Pin Punch Set (Sizes: 3/32, 1/8, 3/16, 1/4)	
Hammer	
8-1/2" Machinist Scribe	

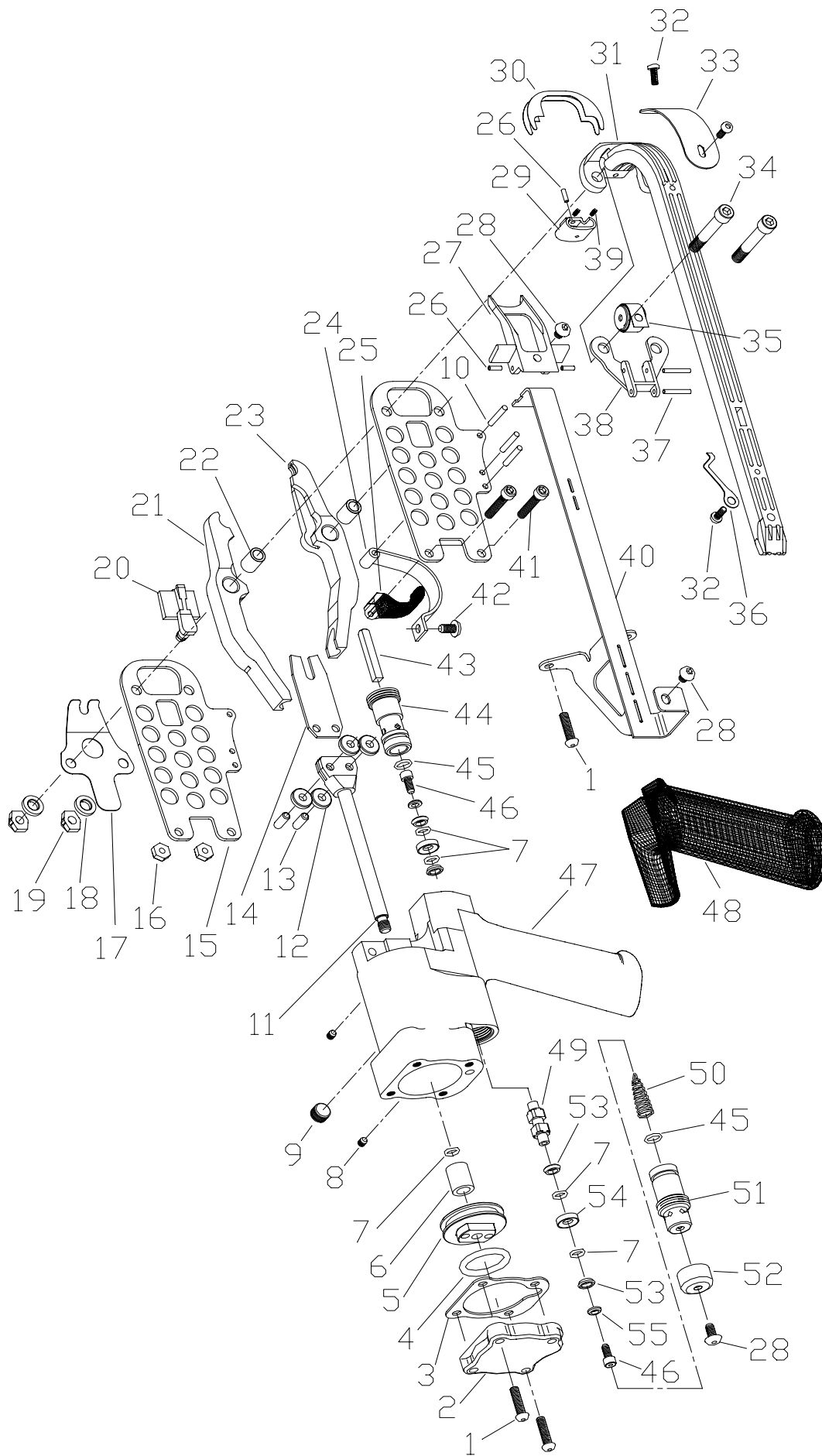

## TO DISASSEMBLE

### Jaws, magazine and pusher assembly

1. Remove screw (#28) from magazine and feeder guide rail (#31 and #40).
2. Remove (2) button head screws (#1) from rear of feeder guide rail.
3. Remove lock nuts, washers and latch spring (#19, #18 and #17) from jaw bolts (#34).
4. Remove jaw bolts from tool, this allows the magazine and pusher assemblies, latch (#20) and jaws (#21 and #23) with jaw bushings (#22) to be removed from the tool.

### Feeder blade and rollers

1. Remove button head screw (#42) from trigger guard (#24).
2. Remove (2) socket head cap screws (#41) with lock nuts (#16).
3. Remove side plates, trigger guard, trigger and roll pins (#15, #24, #25 and #10).
4. Remove (4) rollers, (2) roller pins and feeder blade (#12, #13 and #14).

### Piston and Piston Rod

1. Remove remaining button head screws (#1) from rear of tool.
2. Remove end cap and end cap gasket (#2 and #3).
3. Slide piston rod (#11) completely through tool housing, exposing the end of the piston (#5).
4. Place tool into vise clamping down on flat areas of piston rod (do not over-tighten so as not to deform feeder blade slot).
5. Apply heat as needed to break down thread lock adhesive on threaded end of piston rod.
6. Remove piston (#5) with 9/16" open end or adjustable spanner wrench.
7. Piston rod (#11) may now be removed from front of tool.
8. Remove piston rod o-ring (#7) using machinist scribe from the clearance hole at the front of tool (side plate mtg. end).

### Throttle

1. Remove air deflector parts (#28 and #52).
2. Loosen set screws (#8) on both ends.
3. Remove rear valve seat (#51).
4. Remove throttle spring (#50).
5. Remove front valve seat (#44) and throttle stem (#43) using a 3/16" wrench.
6. Using two 9/64" Allen wrenches, unscrew throttle valve screws (#46) to remove valve units. **Hint:** Hold tool so that the valve is vertical to help prevent loosening parts.
7. One valve screw will remain with other valve parts on throttle valve spacer (#49), and can be disassembled after removal from housing.
8. 1/8" NPT plug (#9) is to be removed only during manifold kit installation.

## TO RE-ASSEMBLE

1. Assemble one side of the o-ring support assembly (#46, #55, #53, #7, #54, #7, and #53) on throttle valve spacer (#49). The chamfer on both washers (#55) should be installed, with chamfer side against cap screw head (#46).
2. Hold tool vertically and install o-ring support assembly with spacer into throttle bore from the top.
3. Holding cap screw with a 9/64" Allen wrench, bring second o-ring support assembly (mounted on screw (#46)) in from the opposite side and complete valve assembly. The valve should have free motion of travel of about 3/32" [.09"(2.3mm)].
4. Insert throttle stem (#43) into front valve seat (#44) and slowly screw front valve seat with lubricated o-ring (#45) into front of the valve bore. (See *Throttle Valve Adjustment Procedure*).
5. Insert valve spring (#50) into the rear of the valve assuring that the locator is inserted into hex of the cap screw (#46).
6. Screw rear valve seat (#51) with lubricated o-ring (#45) into rear of the valve port.

7. Install o-ring (#7) into housing from the front using the piston rod clearance hole.
8. Slide piston rod (#11) into front of housing. Be careful not to damage o-ring (#7) when pushing piston rod into housing, use lubrication.
9. Place o-ring (#4) onto piston (#5).
10. Apply Loctite #242 or equivalent onto threads of piston rod (#11).
11. Slide piston with o-ring into housing end, aligning piston with piston rod. Be careful of piston o-ring when inserting piston, use lubrication.
12. Use 9/16" open end or adjustable spanner wrench to tighten piston while holding flat areas of piston rod.
13. Mount the end cap (#2) with notch in gasket (#3) properly aligned to the housing using only two button head screws (#1), leaving the mounting area for feeder guide rail open.
14. Mount feeder blade (#14) and two roller pins (#13) on piston rod (#11).
15. Place rollers (#12) on the roller pins (#13). Lubrication will hold the rollers in place while assembling the rest of the tool.
16. Assemble trigger and trigger guard (#25 and #24) to the side plates with (3) roll pins (#10).
17. Verify that valve stem is still inserted into front valve seat.
18. Slide side plates (#15) with trigger and trigger guard into place on the housing (slight force may be used to place the side plates onto the key on housing).
19. Insert (2) socket head cap screws (#42) from magazine side of tool and install lock nuts (#16).
20. Leave the trigger guard loose for adjusting the valve. See *Throttle Valve Adjustment Procedure* for proper valve adjustment instructions.
21. Insert roll pins (#26) into pusher (#27) from both sides.
22. Install pusher onto feeder guide rail (#40) by sliding feeder guide rail through the spacer between the roll pins and the pusher body. Make sure that the pusher is in the proper orientation (see parts diagram).
23. Mount constant force spring (#35) onto spring spool bracket (#38) using roll pin (#37). Make sure that spring is in the proper orientation (see parts diagram).
24. Install feeder guide rail onto spring spool bracket using roll pin (#37).
25. Attach the constant force spring (#35) onto pusher with button head cap screw (#28) (feed the spring through the large opening in pusher).
26. Attach feeder guide rail to rear of housing using button head cap screws (#1).
27. Mount latch (#20) onto side plate (#15) side opposite the magazine.
28. Install jaw bushings (#22) into jaws (#21 and #23). Lubricate both jaws and bushings before installing them.
29. Place jaws with bushings between the side plates.
30. Slide magazine assembly into position between spring spool bracket and side plate. Attach the magazine assembly to the rear of the feeder guide rail using button head cap screw (#28). But do **not** tighten completely.
31. Place (1) .010" magazine shim (#30) under the magazine foot, between magazine and side plate. Other shims may be added or subtracted to get the proper drop in the magazine shoe. See *Magazine Adjustment Procedure*.
32. Insert jaw bolts (#34) through the spring spool bracket, magazine, shims, side plate, jaw bushing, side plate, latch spring (#17) and washers (#18). Secure jaw bolts with nylock nuts (#19). Do not over tighten jaw bolts, jaws must still pivot freely.
33. Tighten button head cap screw (#28) at the rear of magazine.
34. After all adjustments to the tool are made, the trigger guard is secured with button head screw (#43).

## INSTALLATION PROCEDURE / ADJUSTMENTS

### Magazine

1. Before tightening jaw bolts (#34), insert approximately .010" of shims.
2. Tighten bolts and check magazine shoe (#29) for proper fit
3. When shimmed correctly, and with the feeder blade in the forward position, the shoe should have approximately .010"(.25mm) float up and down.
4. Cycle tool and check for proper ring closure. If feeder blade hits rear of shoe, add another shim. Shims (#30) are available in two thickness' of .005"(.013mm) and .010"(.25mm).
5. When the tool is completely re-assembled, check to insure that magazine (#31) is parallel to housing (#48).

### Throttle valve

Follow these steps after completing tool assembly in order to minimize the time and effort required for optimum throttle valve adjustment:

1. Using the valve stem, slowly screw in the front valve seat (#44) until it bottoms, then back it out 1-1/2 turns.
2. Do the same with the rear valve seat (#51).
3. Attach an air line and fully depress the trigger. **AIR SHOULD LEAK OUT THE REAR VALVE SEAT. While depressing the trigger**, slowly turn in the rear valve seat (#51) until the air stops leaking.
4. Release the trigger. **AIR SHOULD LEAK OUT OF THE HANDLE.** Place a 3/16 wrench on the trigger valve stem (#43) and turn the front valve seat (#44) in slowly until the air stops leaking from the handle.
5. Gently depress the trigger. Air should flow evenly from the rear exhaust to the handle exhaust.
6. The valve should now be adjusted - test the tool.
7. Tighten the front and rear valve seat locking set screws (#8) and re-test the tool.

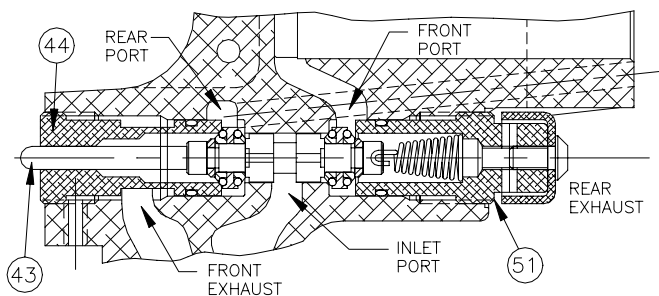

### TOOL LEAKS AIR OR IS SLUGGISH

1. If tool is leaking air in the throttle area, see "Throttle Valve Adjustment" section.
2. Should the tool leak air in both the triggered and rest positions, a damaged piston o-ring may be the cause. Once the piston o-ring has been replaced, lubricate with lithium grease.
3. Put a few drops of light oil into the inlet fitting to lubricate the piston o-ring if tool is running sluggish.
4. If the tool is operating too quickly for the operator, remove button head cap screw (#28) and replace with set screw, jam nut and shakeproof washer (part numbers SC25, SC15 and SC28). The set screw can be used as an air flow control device.

## CONVERTING TO A LEFT HANDED TOOL

1. Remove (2) jaw bolts, nuts, washers and (1) latch spring (#34, #19, #18, and #17).
2. Remove (4) button head cap screws (#1).
3. Remove magazine assembly and pusher system.
4. Remove latch (#20) and move to other side.
5. Remove jaws (#21 and #23) and replace them back in the opposite way.
6. Place magazine assembly and pusher system onto other side
7. Replace latch spring and fasteners.

### LUBRICATION

1. The "SC" series Flex-C tools are designed for long, trouble-free service with minimal air line lubrication. (If an in-line lubricator is used, it should be set at the minimum rate of flow.)
2. Excess oil in the tool will attract dirt, lint, and the adhesive material used in collating the fasteners, preventing smooth operation. When lubrication is used, always use a good **grade of 5W non-detergent oil with no additives.**
3. When servicing or repairing tool use **lithium grease** on all moving parts.

### FILTER AND REGULATOR

The air line should always contain a filter and regulator unit to provide the tool with a constant flow of clean, dry air. If moisture and contaminants are allowed to enter the tool, the tool's serviceable life will be decreased.

### TIPS ON EXTENDING TOOL LIFE

The serviceable life of the "SC" series tools can be extended greatly by using the following guidelines:

1. Always use Stanley Fastening Systems brand fasteners. Never replace worn or broken parts with anything other than genuine Stanley Fastening Systems parts. **Generic fasteners** may shorten the life of your Flex-C tool and **will void** the manufacturer's warranty.
2. Keep your tool(s) clean and dry. Always use clean, dry air and never exceed the recommended air pressure.
3. Use of this tool at minimum air pressure required for the work at hand will greatly extend the life of the tool.
4. Exercise caution not to drop equipment. Tools that are dropping onto the floor or ground are a primary reason for parts replacement.

### HELPFUL HINTS FOR FIELD SERVICE TOOL JAMS

1. The most common reason for jamming problems in the SC tool is short cycling. Because of the tool's valve unit, the trigger must be pulled completely to the rear to ensure positive functioning of the valve. If the tool is "short cycled," the feed mechanism will return forward prematurely in an attempt to pick up a second ring. This will most likely cause a jam.
2. If a jam occurs, pull pusher and rings back on magazine. Point tool away from yourself and others, and cycle tool slowly. This should force jammed ring(s) out of jaw mechanism.
3. If procedure "2" does not clear the tool, **disconnect air**, lay tool on a clean flat surface and remove top jaw bolt and nut, and pull top jaw and bushing from tool. Jammed rings are now exposed and may be removed from tool. Remove build up of dirt, lint, and any other foreign debris and check for worn or damaged parts. Re-assemble in reverse order.
4. Replace worn or damaged parts to keep tool operating properly.

SPECIFICATIONS AND TYPES OF MATERIALS AVAILABLE BY PART NUMBER							
Part Number	Per Strip #	Per Box #	Material	Wire Diameter	Ring I.D.	Ring Leg Opening	Operating Range of Tool SC7 - SC7C
RING15100P	100	10,000	Bright Basic	0.070	0.80	0.57	5/16-27/64 3/16-11/32
RING15100PF	100	10,000	Bright Basic	0.070	0.80	0.57	5/16-27/64 3/16-11/32
RING15G100	100	10,000	Galvanized	0.070	0.80	0.57	5/16-27/64 3/16-11/32
RING15SS100	100	10,000	Stainless Steel	0.070	0.80	0.57	5/16-27/64 3/16-11/32

\* Please specify “Blunt” or “Sharp” when ordering rings.

#### RING DOES NOT CLOSE COMPLETELY

1. Check air pressure. Line pressure at the tool should be between 90 and 95 psi (6.3 - 6.7 kg/cm sq.) for most applications. The tool should never be operated at pressures exceeding 100 psi (7.0 kg/cm sq.).
2. A 3/8” (9.5 mm) or larger air line should be used with the “SC” Series Tools. Air lines in excess of 100’ (30.5 meters) in length can cause air volume deficiencies at the tool which will prevent normal operation.
3. Check for foreign debris in the jaw area. This is especially true in the area between the side plates and rollers.
4. The jaws may be worn from extended use. Check the “land” between the receiving grooves of the jaws. If the land is worn excessively, replacing the jaw(s) is recommended.
5. When the tool is used in corrosive applications, light oil should be applied on a regular basis to the jaw bushings and rollers. Unlubricated and/or corroded jaw bushings may cause the tool to function poorly.
6. When ring teardrops, the latch is not backing the ring up properly. Replace or reshape latch spring to hold latch against the side plate. The latch may also need replaced to get proper ring shape.

#### FEEDING PROBLEMS

1. If rings do not feed smoothly down the magazine, check pusher spring for proper tension. If the magazine is covered with dirt from field use, clean the magazine and apply a light coating of oil.
2. When rings feed properly on the magazine but do not feed into the jaws without spitting out of the magazine side of the tool, or if the rings sit in the jaw grooves on an angle, check jaws to insure freedom of movement. With the jaws void of rings, the vertical movement should be approximately .06” (1.5 mm). The jaw bolt nuts should be snug, but **never over-tightened**.
3. After considerable use or several jams, the fingers on the pusher may show signs of spreading. This may cause the pusher to “hang up” on the magazine, with little or no pressure behind the rings. The last few rings in the strip will not feed into the jaw mechanism. The pusher fingers can be squeezed back into proper position or the pusher should be replaced. **NEVER USE LOOSE RINGS IN THE SC TOOL.**

#### LIMITED WARRANTY

Stanley Fastening Systems warrants to the original retail purchaser that this product is free from defects in material and workmanship, and agrees to repair or replace, at Stanley Fastening Systems’ option, any defective product within 60 days from the date of purchase. This warranty is not transferable. It only covers damage resulting from defects in material or workmanship, and it does not cover conditions or malfunctions resulting from normal wear, neglect, abuse, or accident.

THIS WARRANTY IS IN LIEU OF ALL OTHER EXPRESS WARRANTIES. ANY WARRANTY OF MERCHANTABILITY OR FITNESS FOR A PARTICULAR PURPOSE IS LIMITED TO THE DURATION OF THIS WARRANTY. STANLEY FASTENING SYSTEMS SHALL NOT BE LIABLE FOR ANY INCIDENTAL OR CONSEQUENTIAL DAMAGES.

Some states do not allow limitations on how long an implied warranty lasts, or the exclusion or limitation of incidental or consequential damages, so the above limitations or exclusions may not apply to you. This warranty gives you specific legal rights, and you may also have other rights which vary from state to state.

To obtain warranty service, you must return the product at your expense together with the proof of purchase to a Stanley-Bostitch Regional warranty repair center or you may call us at 1-800-556-6696 or 1-800-832-3080 for the location of additional authorized warranty service locations in your area.

