

SL150-1  
CONTACT ACTUATED TRIGGER ASSEMBLY(BLACK)



FIGURE 1

SL150-2  
SEQUENTIAL ACTUATED TRIGGER ASSEMBLY(GREY)

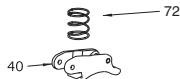

FIGURE 2

SL150-3  
TRIGGER ACTUATED ASSEMBLY

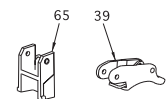
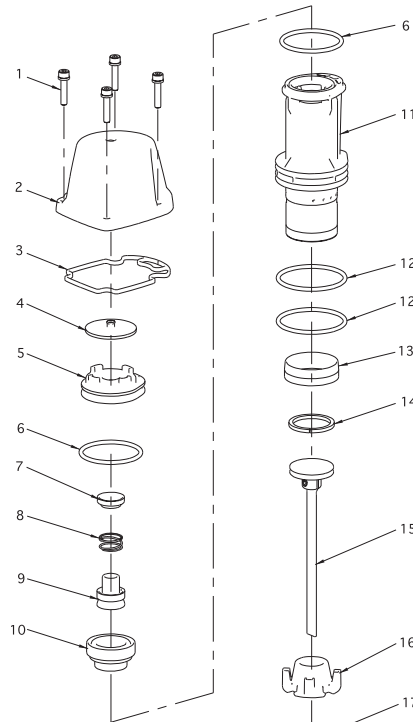

FIGURE 3

18-25 IN-lbs.  
OF TORQUE  
(21-29 CM-KG)  
4 PLACES



# SX150

## INDUSTRIAL OIL FREE STAPLER

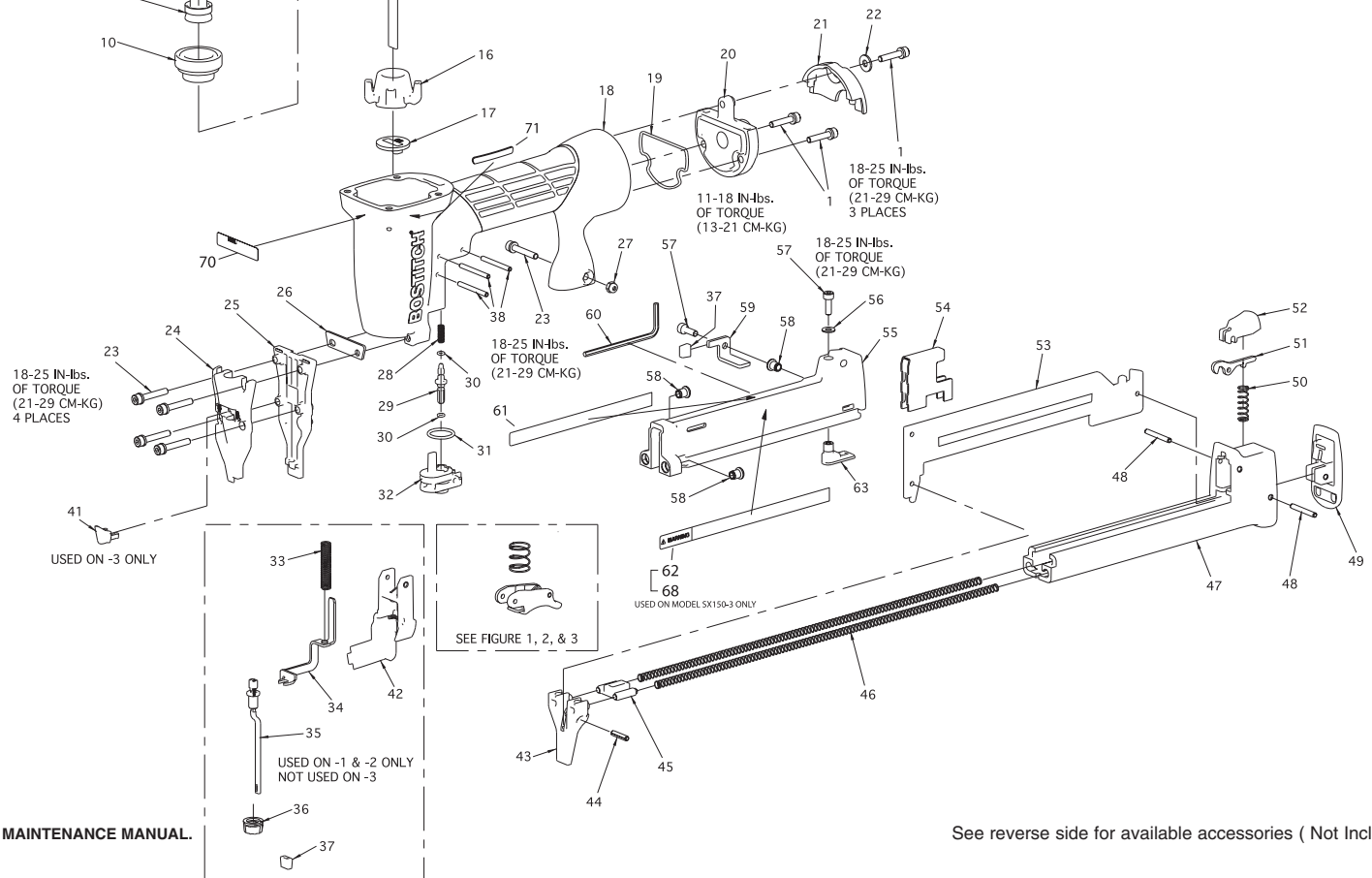

## Spare Parts for SX150

Item#	Illus. #	Description
121051	1	SCREW,SHCS,M4X0.70X20
120996	2	CAP,FRAME
113337	3	SEAL,FRAME/CAP
120988	4	SEAL, TOP
121042	5	HOLD DOWN,HEADVALVE
101058	6	O-RING,1.487X.103
120989	7	SEAL,INSERT
120991	8	SPRING,HEADVALVE
120032	9	INSERT,HEADVALVE
120027	10	DIAPHRAM,HEAD VALVE
120028	11	SLEEVE,BT200
RG161210	12	O-RING,1.612X.103 NBR
120061	13	SEAL,CHECK
S32109	14	RING,PISTON
121280	15	ASSEMBLY,PISTON/DRIVER
120063	16	BUMPER,DRIVE
121025	17	GUIDE,DRIVER
121004	18	FRAME,OVERMOLD
121035	19	SEAL,FRAME END CAP
121031	20	CAP,END BOTTOM
121032	21	DEFLECTOR,CAP END
PW8	22	WASHER,PWR,.188
121052	23	SCREW,SHCS,M4X0.70X25
120058	24	COVER,TRIP
121283	25	NOSE
121279	26	PLATE,DRIVER
MHE4070-100	27	ELASTIC STOP NUT,M4
N86115	28	COMPRESSION SPRING
121029	29	STEM,VALVE

MRG002514	30	O-RING,.098X.055
86998	31	O-RING,.551X.070 NBR
121005	32	HOUSING,VALVE
121024	33	SPRING,TRIP
120022	34	TRIP,UPPER
120140	35	ASSEMBLY,LOWER ARM
120024	36	THUMBWHEEL
120056	37	FOOT,TRIP
100298	38	PIN,SPIRAL M3X30
107581	39	ASSEMBLY,C.T.TRIGGER
107582	40	ASSEMBLY,S.T.TRIGGER
121013	41	PLUG,COVER
120020	42	GUIDE,ARM
116951	43	TIP,CORE
125357	44	PIN,SPIRAL,1/8X5/8 LG. HD
116953	45	SHUTTLE,PUSHER
S32065	46	SPRING,PUSHER
119490	47	MAGAZINE
102549	48	PIN,SPECIAL SPIROL M3XM25
119516	49	BUMPER,REAR
113579	50	SPRING,LATCH
116933	51	LATCH
113568	52	LATCH,COVER
119518	53	CORE
119481	54	PUSHER
119480	55	MAGAZINE,FIXED
MPW4	56	WASHER,PWN,M4
MSC4070-12	57	SCREW,SHCS,M4X0.70X12
S32011	58	INSERT,M4
116941	59	STOP,CORE
121036	60	KEY,HEXAGON 3MM

121288	61	LABEL,FASTENER SPEC.'S (SX150)
121285	62	LABEL,WARNING
121284	63	STOP,LATCH
121008	65	STOP,TRIGGER
121286	68	LABEL,WARNING
121289	70	LABEL,SX150
142961	71	LABEL,MAGNESIUM
100387	72	SPRING,COMPRESSION