

Assembly Diagram for S 18SA

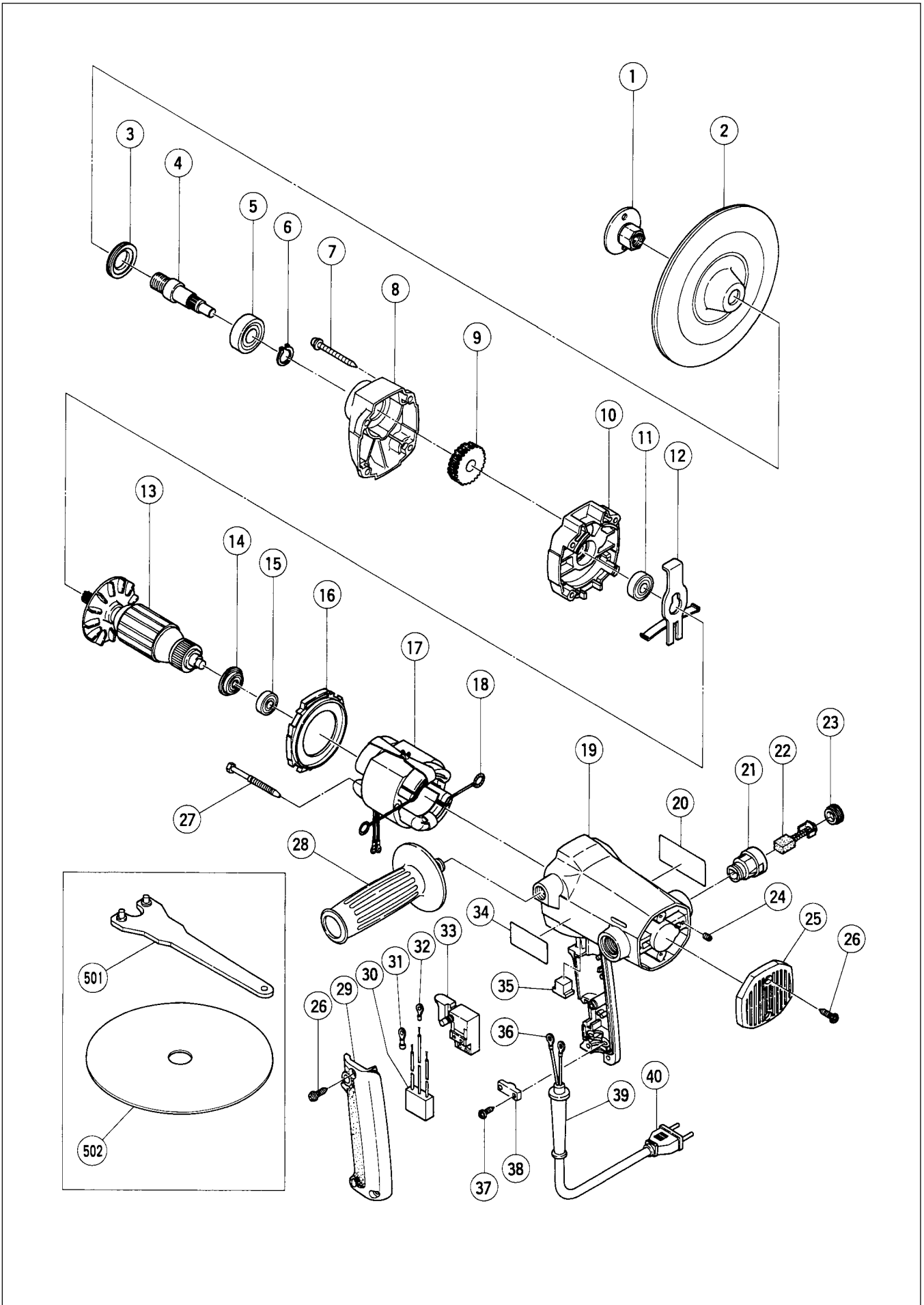

PARTS

S 18SA

ITEM NO.	CODE NO.	DESCRIPTION	NO. USED	REMARKS	
* 1	953-381	WASHER NUT	1		
* 1	953-246Z	WASHER NUT M14	1	FOR ITA,FRG,FRA,ESP	
* 1	953-254P	WASHER NUT 5/8"-11UNC	1	FOR USA	
* 2	953-255	RUBBER PAD (D16 HOLE)	1		
* 2	953-247Z	RUBBER PAD (D14 HOLE)	1	FOR ITA,FRG,FRA,ESP	
	3	944-005	BEARING CAP	1	
* 4	317-895	SPINDLE	1		
* 4	317-902	SPINDLE	1	FOR ITA,FRG,FRA,ESP	
* 4	317-903	SPINDLE	1	FOR USA	
	5	620-1DD	BALL BEARING 6201DDCMPS2L	1	
	6	939-542	RETAINING RING FOR D12 SHAFT (10 PCS.)	1	
	7	316-321	TAPPING SCREW (W/FLANGE) D5X45	4	
	8	318-017	GEAR COVER	1	
	9	997-707	FIRST GEAR	1	
	10	317-891	INNER COVER	1	
	11	600-0DD	BALL BEARING 6000DDCMPS2L	1	
	12	317-890	LOCK LEVER	1	
* 13	360-499U	ARMATURE ASS'Y 110V-115V	1	INCLUD.11,14,15	
* 13	360-499E	ARMATURE 220V-230V	1		
	14	317-889	DUST SEAL	1	
	15	608-VVM	BALL BEARING 608VVC2PS2L	1	
	16	317-888	FAN GUIDE	1	
* 17	340-446C	STATOR ASS'Y 110V	1	INCLUD.18	
* 17	340-446E	STATOR ASS'Y 220V-230V	1	INCLUD.18	
* 17	340-446H	STATOR ASS'Y 220V-230V	1	INCLUD.18 FOR ITA,FRG,FRA,ESP,CHN	
	18	930-703	BRUSH TERMINAL	2	
	19	317-896	HOUSING ASS'Y	1	INCLUD.21,24
	20		NAME PLATE	1	
	21	958-900	BRUSH HOLDER	2	
	22	999-043	CARBON BRUSH (1 PAIR)	2	
	23	945-161	BRUSH CAP	2	
	24	938-477	HEX. SOCKET SET SCREW M5X8	2	
	25	317-894	TAIL COVER	1	
	26	302-086	TAPPING SCREW (W/FLANGE) D4X20 (BLACK)	5	
	27	953-174	HEX. HD. TAPPING SCREW D5X55	2	
	28	937-981	SIDE HANDLE FOR M14	1	
	29	317-892	HANDLE COVER	1	
* 30	994-273	NOISE SUPPRESSOR	1	FOR ITA,FRG,FRA,ESP,CHN	
* 31	311-741	TERMINAL	2	FOR NOISE SUPPRESSOR	
* 32	959-144	TERMINAL 50051 (10 PCS.)	1	FOR NOISE SUPPRESSOR	
	33	302-477	SWITCH (C) (1P SCREW TYPE) W/LOCK	1	
	34		HITACHI LABEL	1	
	35	317-893	DUST PACKING	1	
	36	980-063	TERMINAL	2	FOR CORD
	37	984-750	TAPPING SCREW (W/FLANGE) D4X16	2	
	38	960-266	CORD CLIP	1	
	39	953-327	CORD ARMOR D8.8	1	
* 40	500-234Z	CORD	1	(CORD ARMOR D8.8)	
* 40	500-455Z	CORD	1	(CORD ARMOR D8.8) FOR CHN,THA	
* 40	500-423Z	CORD	1	(CORD ARMOR D8.8) FOR SIN	
* 40	500-237Z	CORD	1	(CORD ARMOR D8.8) FOR HKG	

* : ALTERNATIVE PARTS

5 - 99

