

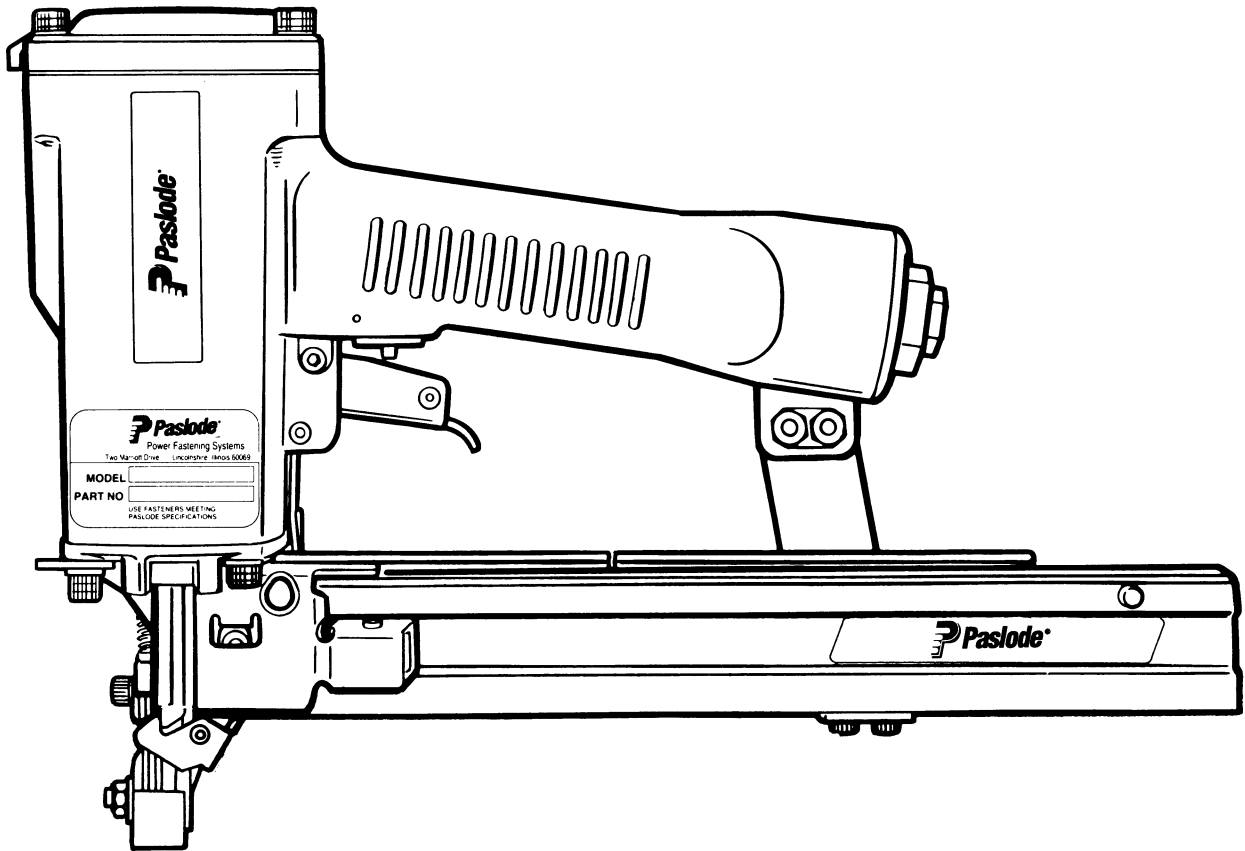

MODEL 3200/50-S16 DL  
STAPLER



TOOL SCHEMATIC AND PARTS

**IMPORTANT!**

**DO NOT DESTROY**

Always refer to safety and maintenance manuals #403606, #405222 and #405218 for detailed information on these tools. It is the customer's responsibility to have all operators and service personnel read and understand this information.

# PARTS LEGEND 3200/50-S16 DL, 403764

1	404229	4	Socket Head Capscrew, 1/4-20 x 2-1/4"	47	402781	1	Rail Bracket
3	404242	1	Diffuser Cap	48	004224	5	Socket Head Capscrew, #10-32 x 3/8"
4	006310	1	Socket Head Capscrew, #6-32 x 1/2"	49	404054	1	Seal, Main Valve
5	002187	4	Lock Washer, 1/4"	50	090927	1	"O" Ring, Main Valve
6	402705	1	Cap	51	403326	1	Rail Cover Spring Stop
7	402717	1	Conical Spring	52	402629	2	Hardened Washer
*8	404230	1	Retaining Ring	53	402794	1	Intermediate Work Contacting Element
*9	091537	1	"O" Ring, Main Valve Assembly	*54	402738	1	Spring
10	404122	1	Upper Valve Piston	55	402736	1	Flat Washer, #10
11	404055	1	Post, Main Valve	56	403207	1	Work Contacting Element
*12	404256	1	"O" Ring, Main Valve Post	57	402792	1	Upper Work Contacting Element
*13	402723	1	"O" Ring, Piston	*58	402734	1	Spring
14	403563	1	Piston	59	403204	1	Front Guide
15	403582	1	Jam Nut	▲ 60	404232	2	Socket Head Capscrew, #8-32 x 13/16"
*16	403202	1	Driver Blade	61	404698	2	Roll Pin, Assembly
17	402725	1	Seal, Sleeve	62	403205	1	Back Plate
18	405246	1	Sleeve	63	402730	1	Pivot Pin, Front Guide
*19	402728	1	"O" Ring, Flange	64	092176	1	Roll Pin, 5/32" Dia. x 1-3/8" Lg.
*20	402729	1	"O" Ring, Sleeve	65	405079	1	Spring, Front Guide Latch
21	403854	1	Retaining Bumper	66	403206	1	Latch, Front Guide
22	403853	1	Bumper	**67	500459	1	Warning Label
23	402785	1	Seal, Drive Blade	68	402780	1	Pivoting Rail Cover Assembly
24	402707	1	Gasket, Cap	69	403766	1	Rail and Rail Cover Assembly
25	402701	1	Housing	70	402731	1	Logo, Rail
26	404939	2	Logo, Housing	71	402740	1	Roll Pin, 3/32" Dia. x 7/16" Lg.
27	096893	1	Nameplate	72	402798	1	Latch, Follower Button
28	402708	1	Gasket, Flange	73	402799	1	Spring, Follower Latch
29	402706	1	Flange	74	402797	1	Retaining Bushing
30	091545	4	Socket Head Capscrew, 1/4-20 x 7/8"	75	091568	1	Binding Head Screw, #6-32 x 1/4"
31	406006	1	Sequential Trigger	*76	090449	1	Negator, Double Length
32	402079	1	Pin, Trigger	77	403744	1	Drum, Negator
33	402668	1	Retaining Washer	78	402743	1	Pin, Negator Drum
36	091966	1	"O"-Ring	79	402796	1	Follower
37	026133	2	Roll Pin, 1/8" Dia. x 1" Lg.	80	404325	1	Stop Nut
38	401958	1	Valve Body	81	091447	4	Flat Washer, 1/4"
*39	092174	1	"O" Ring, Valve Body	82	404243	4	Spacer, Diffuser
40	097746	1	Valve Pin	*84	092775	1	"O" Ring, Main Valve
41	097748	1	Spring, Valve Pin	*85	092773	1	"O" Ring, Main Valve
*42	091591	1	"O" Ring, End Plug	86	404056	1	Lower Valve Piston
43	401940	1	End Plug	87	400007	1	Clip
44	091622	1	Reducing Pipe Bushing	88	405243	1	Flange
45	004502	2	Socket Head Capscrew, #10-32 x 5/8"	89	500488	1	Grip, Handle
46	092037	3	Lock Nut, #10-32	90	403716	2	Socket Head Capscrew #10-32 x 5/16"

\* Denotes normal wear items.

\*\* Make sure warning label (500459) is properly affixed. Replace if necessary. Label available at no charge through the Service Dept.

▲ Apply Loctite 242 (Blue)

➔ Denotes new change

**AIR CONSUMPTION CHART**

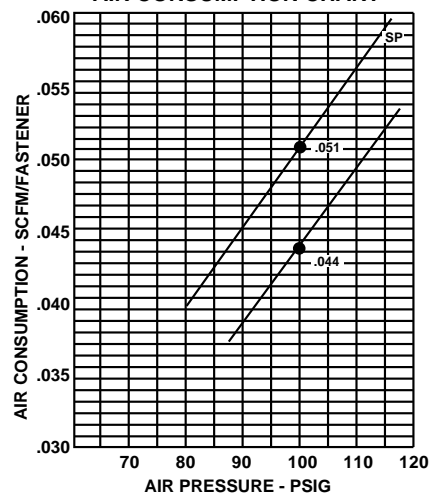

3200/50-S16 DL

403764

Cap Assembly  
#402710

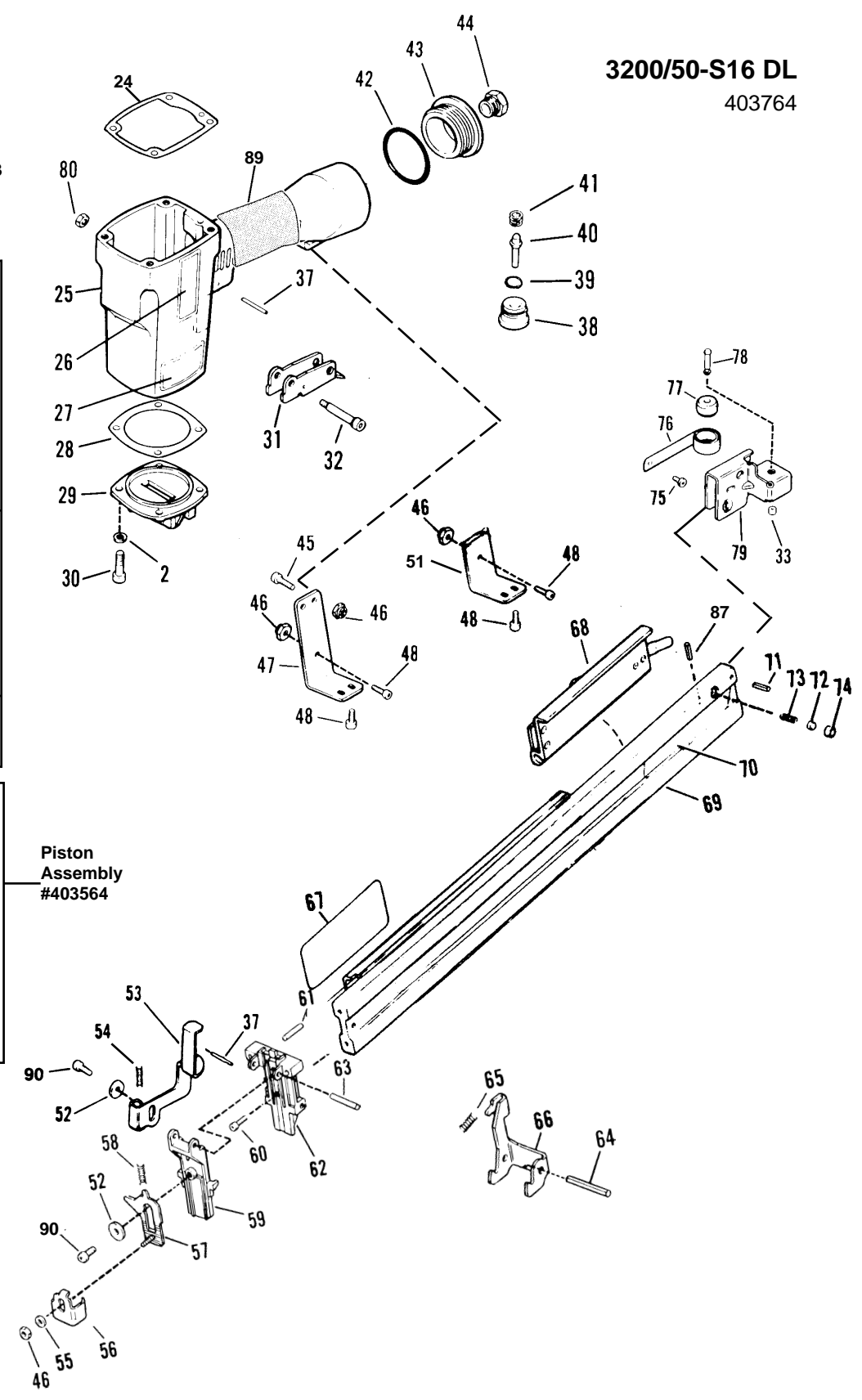
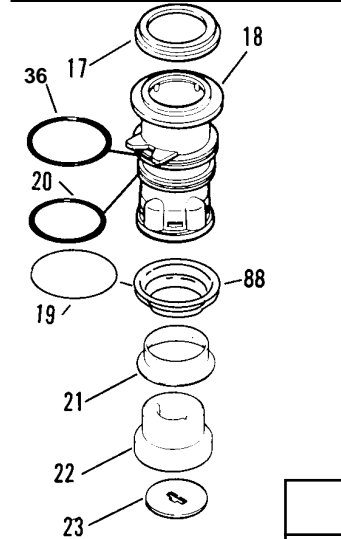
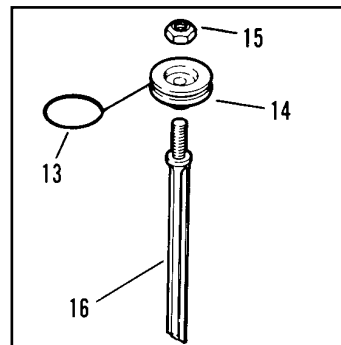
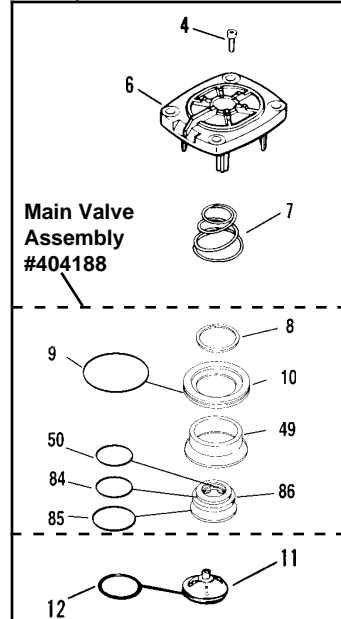

**⚠ WARNING**  
All parts must be periodically inspected and replaced if worn or broken. Failure to do this can affect the tool's operation and present a safety hazard.

# ACCESSORIES

## Remote Fire Valve

This valve via a positive air signal allows a machine mounted tool to be operated from an automatic air valve or foot pedal system.

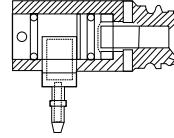

Part No. 1X0713

<p><b>Lubricants and Loctite</b>          Chemplex 710 Lubricant 1 lb.          Part No. 403734          Lubricant Grease 5 gram tubes          Part No. 219188          Loctite 242 (Blue) 1 oz.          Part No. 093500          Lubricating Oil 8 oz.          Part No. 219026          Lubricating Oil 8 oz. with Antifreeze          Part No. 219090</p>	<p><b>Belt Hook</b>          Attaches to cap of tool enabling you to carry tool on belt holder (offered below).          Part No. 219017</p> <p><b>Belt Hook Holder</b>          Attaches to work belt and carries tool using the above belt hook.          Part No. 219028</p>
<p><b>Degreaser Cleaner</b>          Ideal cleaner for all Paslode tools.          Part No. 219086</p>	<p><b>Standard Crown Stapler Repair Kit</b>          This kit repairs all air leaks except for the trigger valve .          Part No. 219223</p>
<p><b>Safety Glasses</b>          Clear          Part No. 402510</p> <p>Tinted          Part No. 402512</p>	<p><b>Trigger Valve Repair Kit</b>          This kit repairs all trigger valve air leaks.          Part No. 219224</p>

# SAFETY INSTRUCTIONS

## WEAR EYE AND HEARING PROTECTION



Always wear hearing protection and eye protection devices, including side shields when operating or working in the vicinity of a tool.



Never use any bottled air or gases such as oxygen to operate the tool since they could cause the tool to explode.

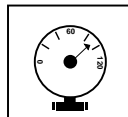
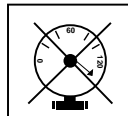

## DO NOT EXCEED MAXIMUM RECOMMENDED AIR PRESSURE

Operate the tool using only the recommended air pressure. Do not exceed the maximum air pressure marked on the tool. Be sure the air pressure gauge is operating properly and check it at least twice a day.



An Illinois Tool Works Company  
 888 Forest Edge Drive  
 Vernon Hills, Illinois 60061