

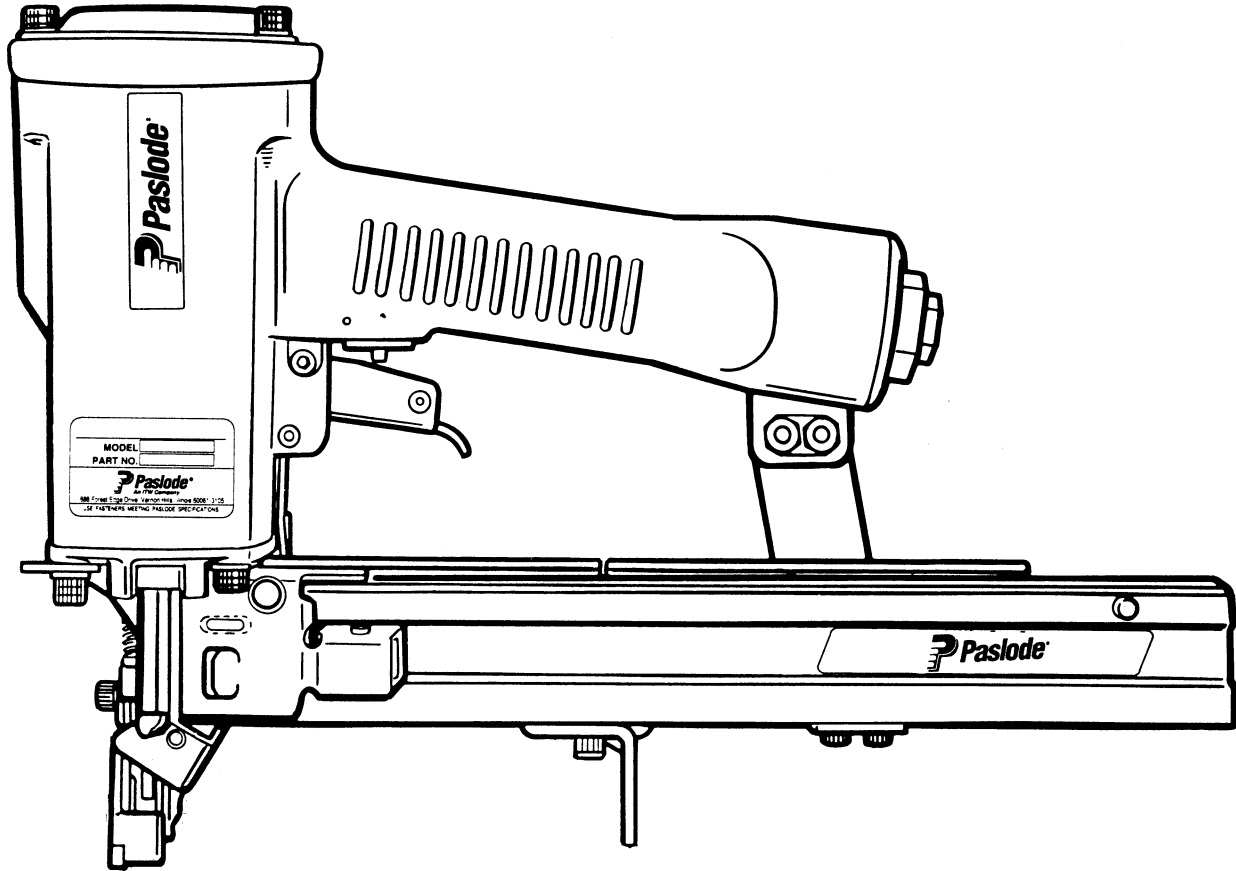

MODEL 3200/50-W16DL SERIES STAPLER



TOOL SCHEMATIC AND PARTS

IMPORTANT! DO NOT DESTROY

Always refer to safety and maintenance manual #403606 for detailed information on this tool. It is the customer's responsibility to have all operators and service personnel read and understand this information.

PARTS LEGEND 3200/50-W16DL, 403460

1	091362	4	Socket Head Capscrew, 1/4-20 x 1-1/2"	45	004502	4	Socket Head Capscrew, #10-32 x 5/8"
➔ 2	002187	4	Lockwasher, 1/4"	46	092037	6	Flexloc Nut, #10-32
3	404242	1	Air Diffuser	47	402781	1	Rail Bracket
4	006310	1	Socket Head Capscrew, #6-32 x 1/2"	▲ 48	004224	4	Socket Head Capscrew, #10 - 32 x 3/8"
➔ 5	070545	2	REMOVED	➔ 49	004238	2	REMOVED
6	402704	1	Cap	50	402629	2	Hardened Washer
7	402717	1	Conical Spring	➔ 51	402737	1	Intermediate W.C.E.
8	404230	1	Retaining Ring	*52	402738	1	Spring
*9	091537	1	"O" Ring, Main Valve Assembly	53	402736	1	Flat Washer, #10
10	404122	1	Upper Valve Piston	54	402997	1	Footed Lower W.C.E.
11	404055	1	Post Main Valve	55	402763	1	Upper Work Contacting Element
*12	404256	1	"O" Ring, Main Valve Post	*56	402734	1	Spring
*13	402723	1	"O" Ring, Piston	57	402773	1	Front Guide
14	403563	1	Piston	58	092773	1	"O" Ring
15	403582	1	Jam Nut	59	404698	2	Roll Pin Assembly
*16	404182	1	Driver Blade	60	404845	1	Back Plate
17	402725	1	Seal, Sleeve	61	402730	1	Pivot Pin, Front Guide
18	405245	1	Sleeve	62	402762	1	Roll Pin, 5/32" Dia. x 1-3/4" Lg.
*19	402728	1	"O" Ring, Sleeve	63	405079	1	Spring, Front Guide Latch
*20	402729	1	"O" Ring, Sleeve	64	402776	1	Latch, Front Guide
21	403854	1	Retainer, Bumper	65	402486	1	Retaining Washer
*22	403855	1	Bumper	**66	500459	1	Warning Sign
23	402754	1	Seal, Driver Blade	67	402780	1	Pivoting Rail Cover Assembly
*24	402707	1	Gasket, Cap	68	404852	1	Rail and Rail Cover Assembly
25	402701	1	Housing	69	402731	1	Logo, Rail
26	404939	2	Logo, Housing	70	400007	1	Clip
27	096893	1	Nameplate	71	402758	1	Latch, Follower
28	402708	1	Gasket, Flange	72	402759	1	Spring, Follower Latch
29	402706	1	Flange	▲ 73	091568	1	Pan Head Screw, #6-32 x 1/4"
30	091545	4	Socket Head Capscrew, 1/4-20 x 7/8"	*74	090449	1	Negator, Double Length
➔ 31	406006	1	Sequential Trigger	75	403744	1	Drum, Negator
32	402079	1	Pin, Trigger	76	402743	1	Pin, Negator Drum
33	402668	1	Retaining Washer	77	402760	1	Follower
34	404054	1	Seal Main Valve	78	403326	1	Rail Cover Spring Stop
*35	090927	1	"O" Ring	79	404325	1	Stop Nut, #8 - 32
*36	092775	1	"O" Ring	80	091447	4	Flat Washer
37	026133	2	Roll Pin, 1/8" Dia. x 1" Lg.	81	404243	4	Spacer, Diffuser
38	401958	1	Valve Body	82	404056	1	Lower Valve, Piston
*39	092174	1	"O" Ring, Valve Body	➔ 83	405147	1	REMOVED
40	097746	1	Valve Pin	➔ 84	005849	1	REMOVED
41	097748	1	Spring, Valve Pin	85	405243	1	Flange, Sleeve
42	091591	1	"O" Ring, End Plug	86	091966	1	"O" Ring
▲ 43	401940	1	End Plug	87	500488	1	Grip, Handle
44	091622	1	Reducing Pipe Bushing	➔ 88	403716	2	Socket Head Cap Screw #10-32 x 5/16"

* Denotes normal wear items.

** Make sure warning label (500459) is properly affixed.
Replace if necessary. Label available at no charge through
the Service Dept.

▲ Apply Loctite 242 (Blue) Part No. 093500

➔ Denotes new change.

PARTS OFFERED AS ASSEMBLIES

404345 Piston Assembly

Includes

13	402723	1	"O" Ring, Piston
14	403563	1	Piston
15	403582	1	Jam Nut
16	404182	1	Driver Blade

404188 Main Valve Assembly

Includes

8	404230	1	Retaining Ring
*9	091537	1	"O" Ring, Main Valve Assembly
10	404122	1	Upper Valve Piston
34	404054	1	Seal, Main Valve
*35	090927	1	"O" Ring, Main Valve Assembly
*36	092775	1	"O" Ring, Main Valve Assembly
*58	092773	1	"O" Ring, Main Valve Assembly
82	404056	1	Lower Valve Piston

→ 402709 Cap Assembly

Includes

4	006310	1	Socket Head Capscrew, #6-32 x 1/2"
5	070545	2	REMOVED
6	402704	1	Cap
7	402717	1	Conical Spring
11	404055	1	Post, Main Valve
12	404256	1	"O" Ring, Main Valve Post
	404188	1	Main Valve Assembly

AIR CONSUMPTION CHART

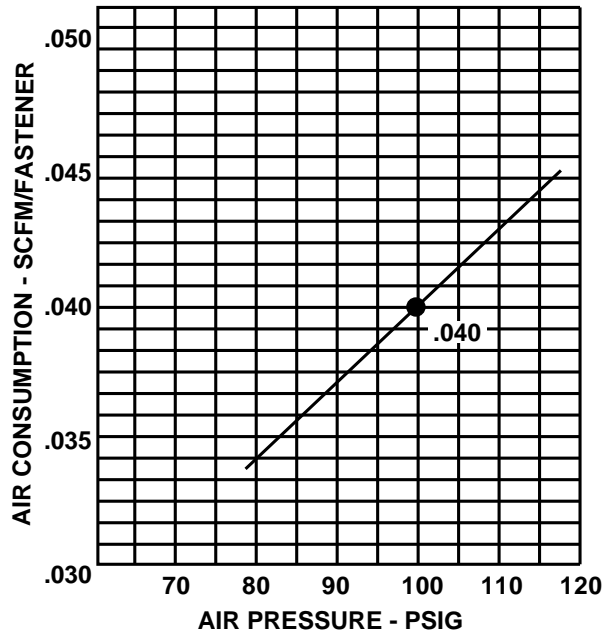

SAFETY INSTRUCTIONS

WEAR EYE AND HEARING PROTECTION

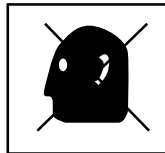

Always wear hearing protection and eye protection devices, including side shields when operating or working in the vicinity of a tool.

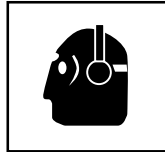

DO NOT EXCEED MAXIMUM RECOMMENDED AIR PRESSURE

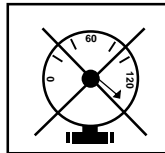

Operate the tool using only the recommended air pressure. Do not exceed the maximum air pressure marked on the tool. Be sure the air pressure gauge is operating properly and check it at least twice a day.

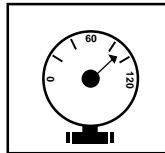

Never use any bottled air or gases such as oxygen to operate the tool since they could cause the tool to explode.

3200/50-W16DL

403460

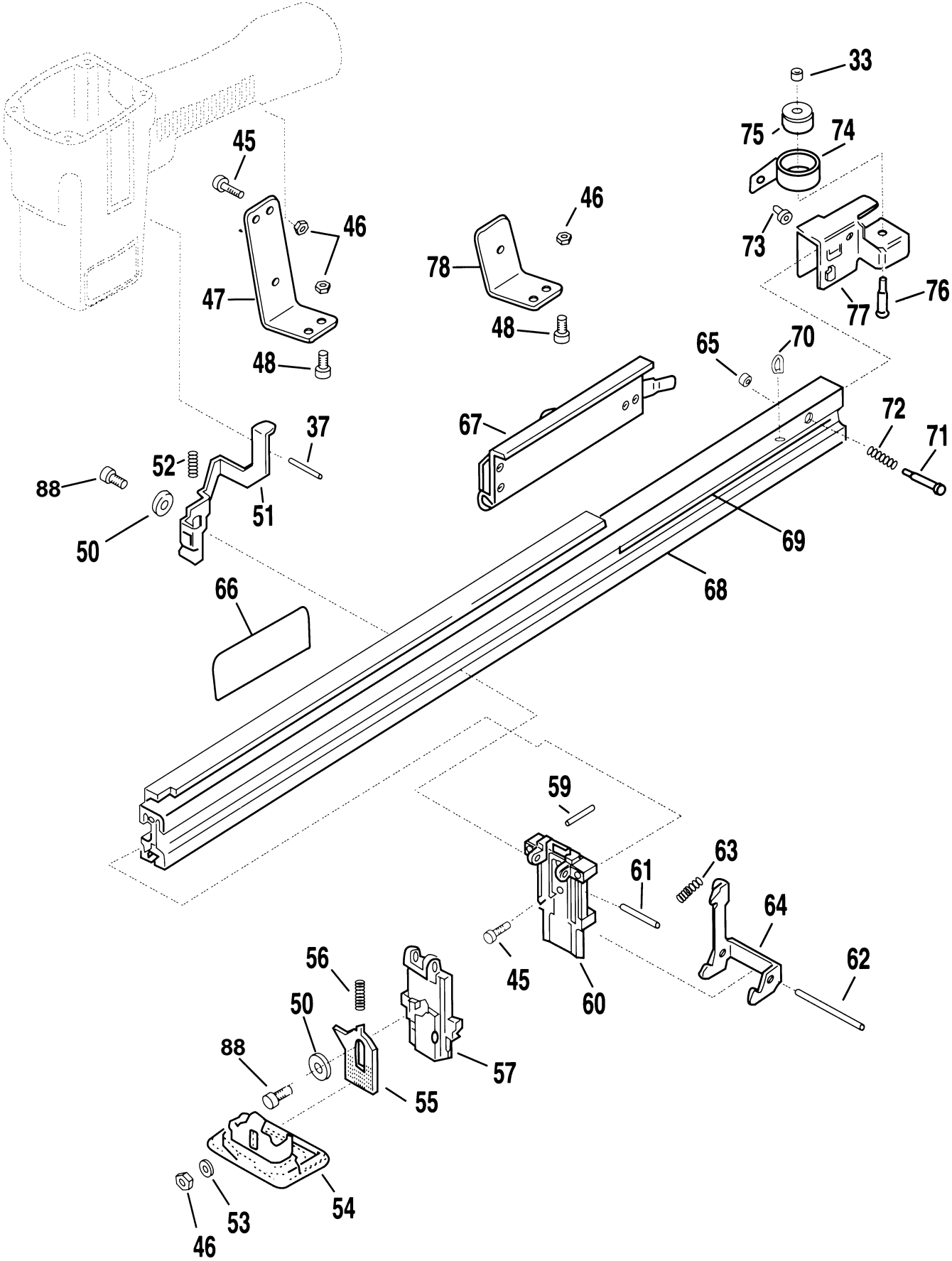

ACCESSORIES

Remote Fire Valve

This valve via a positive air signal allows a machine mounted tool to be operated from an automatic air valve or foot pedal system.

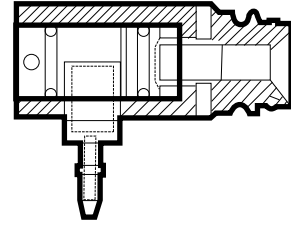

Part No. 1X0713

Lubricants and Loctite

Loctite 242 (Blue) 102

Part No. 093500

Lubricating Oil 8 oz.

Part No. 219026

Lubricating Oil with Antifreeze

Part No. 219090

Chemplex 710 Lubricant 1 lb.

Part No. 403734

Lubricant Grease 5 gram tube

Part No. 219188

Degreaser Cleaner

Ideal Cleaner for all Paslode Tools

Part No. 219086

Belt Hook

Attaches to cap of tool enabling you to carry tool on belt holder.

Part No. 219017

Belt Hook Holder

Attaches to work belt and carries tool using the above belt hook.

Part No. 219028

Safety Glasses

Clear

Part No. 402510

Tinted

Part No. 402512



An Illinois Tool Works Company
888 Forest Edge Drive
Vernon Hills, IL 60061