

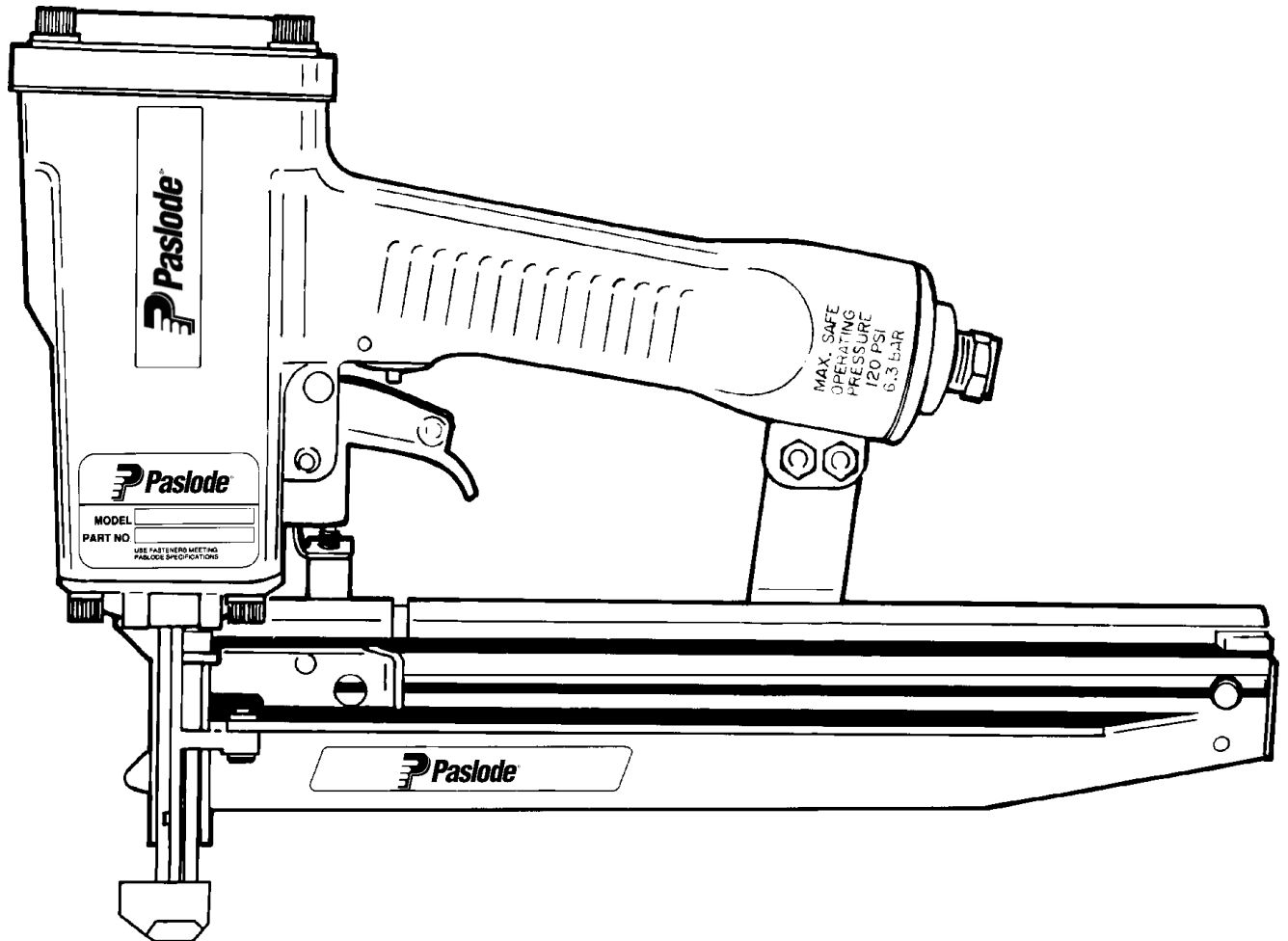

MODEL 3250 /65-F16
FINISH NAILER



TOOL SCHEMATIC AND PARTS

IMPORTANT! **DO NOT DESTROY**

Always refer to safety and maintenance manual #403606 for detailed information on this tool. It is the customer's responsibility to have all operators and service personnel read and understand this information.

PARTS LEGEND 3250/65-F16, 403700

1	091362	4	Socket Head Capscrew, 1/4-20 x 1-1/2"	46	004502	2	Socket Head Capscrew, #10-32 x 5/8"
→ 2	002187	4	Lock Washer, 1/4"	47	4037	1	Rail Bracket Assembly
3	091447	4	Flat Washer	48	402731	1	Logo-Rail
4	404242	1	Cap, Diffuser	49	092037	2	Lock Nut, #10 - 32
5	006310	1	Socket Head Capscrew, #6-32 x 1/2"	50	091966	1	O-Ring
6	402704	1	Cap	51	404289	1	Bracket, Work Contacting Element
7	402717	1	Conical Spring	*52	402738	1	Spring, Work Contacting Element
8	404230	1	Retaining Ring	53	403719	1	Intermediate Work Contacting Element Assembly
*9	091537	1	"O" Ring, Main Valve Assembly	→ 54	004224	2	Socket Head Capscrew, #10 - 32 x 3/8"
10	404122	1	Upper Valve Piston	55	004238	4	Lock Washer, #10
11	404055	1	Post, Main Valve	56	402629	2	Hardened Washer
*12	404256	1	"O" Ring, Main Valve Post	57	405076	1	Spring
*13	402723	1	"O" Ring, Piston	58	403712	1	Front Guide Latch Assembly
14	403563	1	Piston	59	403724	1	Rail Cover Assembly
15	403582	1	Jam Nut	60	403708	1	Negator Assembly
*16	403594	1	Driver Blade	61	403710	1	Roller, Negator
17	402725	1	Seal, Sleeve	62	403702	2	Wear Strip
18	405245	1	Sleeve	63	403745	1	Rail Assembly
*19	402728	1	"O" Ring, Sleeve	64	403707	1	Work Contacting Element
*20	402729	1	"O" Ring, Sleeve	65	404180	1	Tip, Deep Drive (Black)
21	403854	1	Retaining Bumper	66	403715	1	Follower Assembly
*22	403853	1	Bumper	67	403711	1	Latch Pin, Follower
23	403705	1	Seal, Driver Blade	68	091536	1	Spring, Follower Latch Pin
*24	402707	1	Gasket, Cap	69	403713	1	Retaining Ring
25	402701	1	Housing	70	404243	4	Spacer
26	404939	2	Logo, Housing	71	500488	1	Grip, Handle
27	096893	1	Nameplate	72	404274	1	Washer
28	402708	1	Gasket, Flange	73	403812	2	Flat Washer
29	402706	1	Flange	74	009397	2	Capscrew #10-24 x 1/2"
30	091545	4	Socket Head Capscrew, 1/4-20 x 7/8"	**75	500458	1	Warning Label
31	405144	1	Trigger	77	401988	1	Spring, Front Guide Latch
32	402079	1	Pin, Trigger	78	094295	1	"O" Ring
33	404325	1	Stop Nut	79	404054	1	Seal, Main Valve
34	026133	2	Roll Pin, 1/8" Dia. x 1" Lg.	*80	090927	1	"O" Ring, Main Valve
35	402730	1	Pivot Pin, Front Guide	*81	092775	1	"O" Ring, Main Valve
36	404698	2	Roll Pin, Assembly	*82	092773	1	"O" Ring, Main Valve
37	403592	1	Front Guide	83	404056	1	Lower Valve Piston
38	403591	1	Back Plate	84	403599	1	Spacer
39	401958	1	Valve Body	85	403731	1	Rivet
*40	092174	1	"O" Ring, Valve Body	86	405147	1	Lever, Trigger
41	097746	1	Valve Pin	87	005849	1	Roll Pin
42	097748	1	Spring, Valve Pin	88	405243	1	Flange, Sleeve
*43	091591	1	"O" Ring, End Plug	→ 89	403716	4	Socket Head Capscrew 10-32 x 5/16"
44	401940	1	End Plug				
45	091622	1	Reducing Pipe Bushing				

* Denotes normal wear items

** Make sure Warning Label (500458) is properly affixed. Replace if necessary. Label available at no charge through Service Department.

▲ Apply Loctite 242 (Blue)

→ Denotes New Change

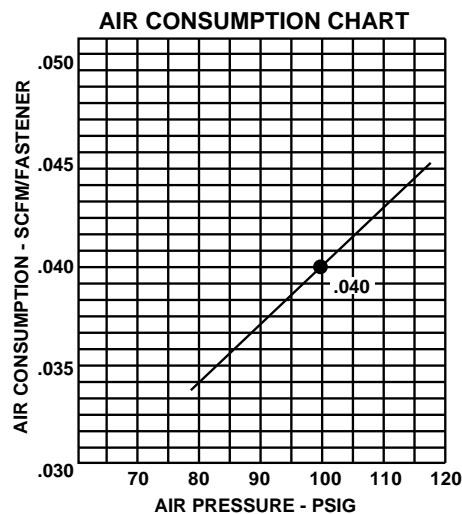

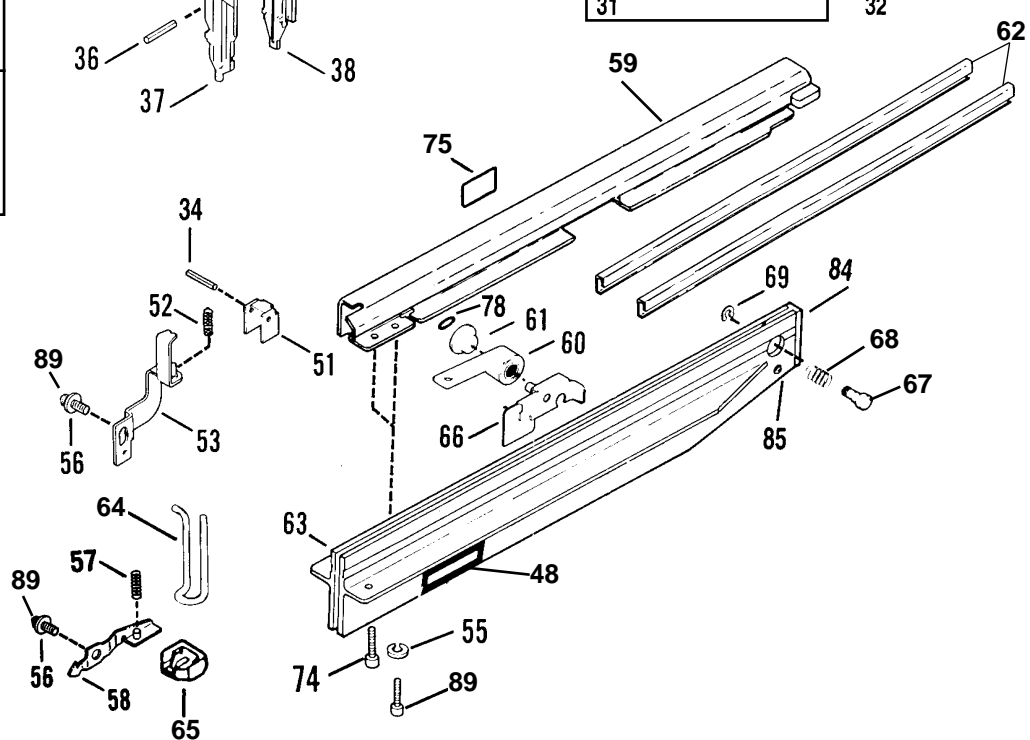
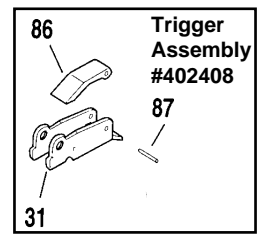
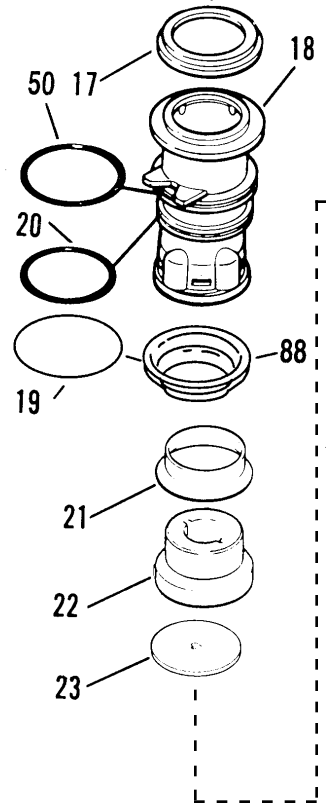
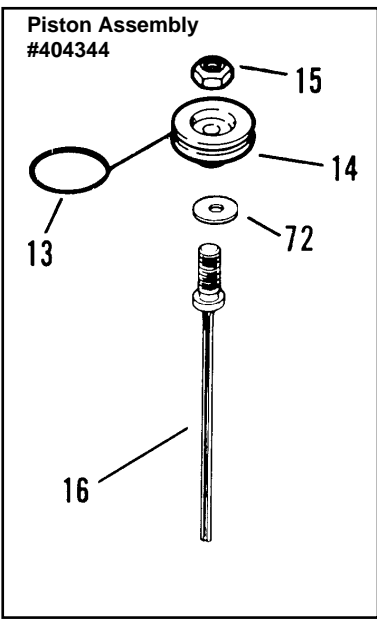
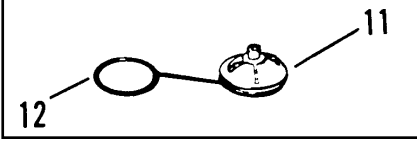
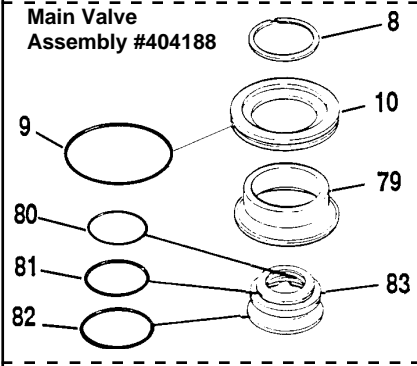
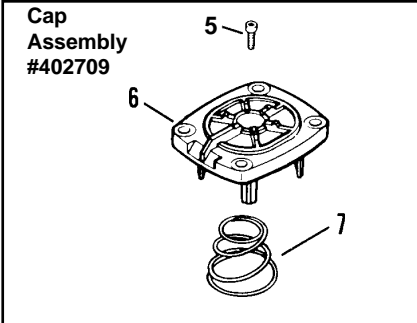
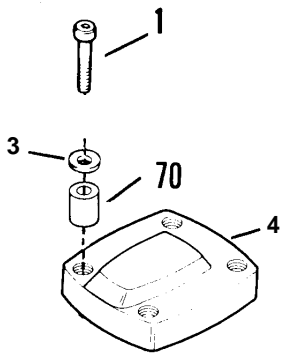

⚠ WARNING

All parts must be periodically inspected and replaced if worn or broken. Failure to do this can affect the tool's operation and present a safety hazard.

ACCESSORIES

Sequential Operating Kit

This special attachment is designed for sequential operation ("stops contact firing"). The operator must depress and hold the work contacting element against the work surface before pulling the trigger. This sequence must be repeated each time the tool drives a fastener.

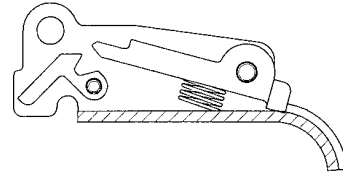

Part No. 406006

Remote Fire Valve

This valve via a positive air signal allows a machine mounted tool to be operated from an automatic air valve or foot pedal system.

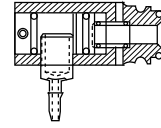

Part No. 1x0713

Lubricants and Loctite

Chemplex 710 Lubricant 1 lb. Part No. 403734
 Lubricating Oil 8 oz. Part No. 219026
 Lubricating Oil with Antifreeze Part No. 219090
 Loctite 242 (Blue) 1 oz. Part No. 093500

Adjustable No-Mar Work Contacting Element Kit

Part No. 219072

Safety Glasses

Clear Part No. 402510
 Tinted Part No. 402512

Back Plate Insert

This insert accommodates 1 1/4" and shorter finish nails. Also prevents nails from tumbling and jamming. Part No. 1X1210

Degreaser Cleaner

Ideal cleaner for all Paslode tools. Part No. 219086

Tool Case

Part No. 404658

Universal Belt Hook

Attaches to cap of tool enabling you to carry tool on belt holder (offered below). Part No. 219017

Finish Nailer Repair Kit

This kit repairs all air leaks except for the trigger valve. Part No. 219221

Belt Hook Holder

Attaches to work belt and carries tool using the above belt hook. Part No. 219028

Trigger Valve Repair Kit

This kit repairs trigger valve air leaks. Part No. 219224

SAFETY INSTRUCTIONS

WEAR EYE AND HEARING PROTECTION

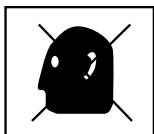

Always wear hearing protection and eye protection devices, including side shields when operating or working in the vicinity of a tool.

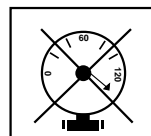

DO NOT EXCEED MAXIMUM RECOMMENDED AIR PRESSURE

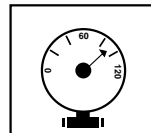

Operate the tool using only the recommended air pressure. Do not exceed the maximum air pressure marked on the tool. Be sure the air pressure gauge is operating properly and check it at least twice a day.

Never use any bottled air or gases such as oxygen to operate the tool since they could cause the tool to explode.



An Illinois Tool Works Company
 888 Forest Edge Dr.
 Vernon Hills, Illinois 60061