

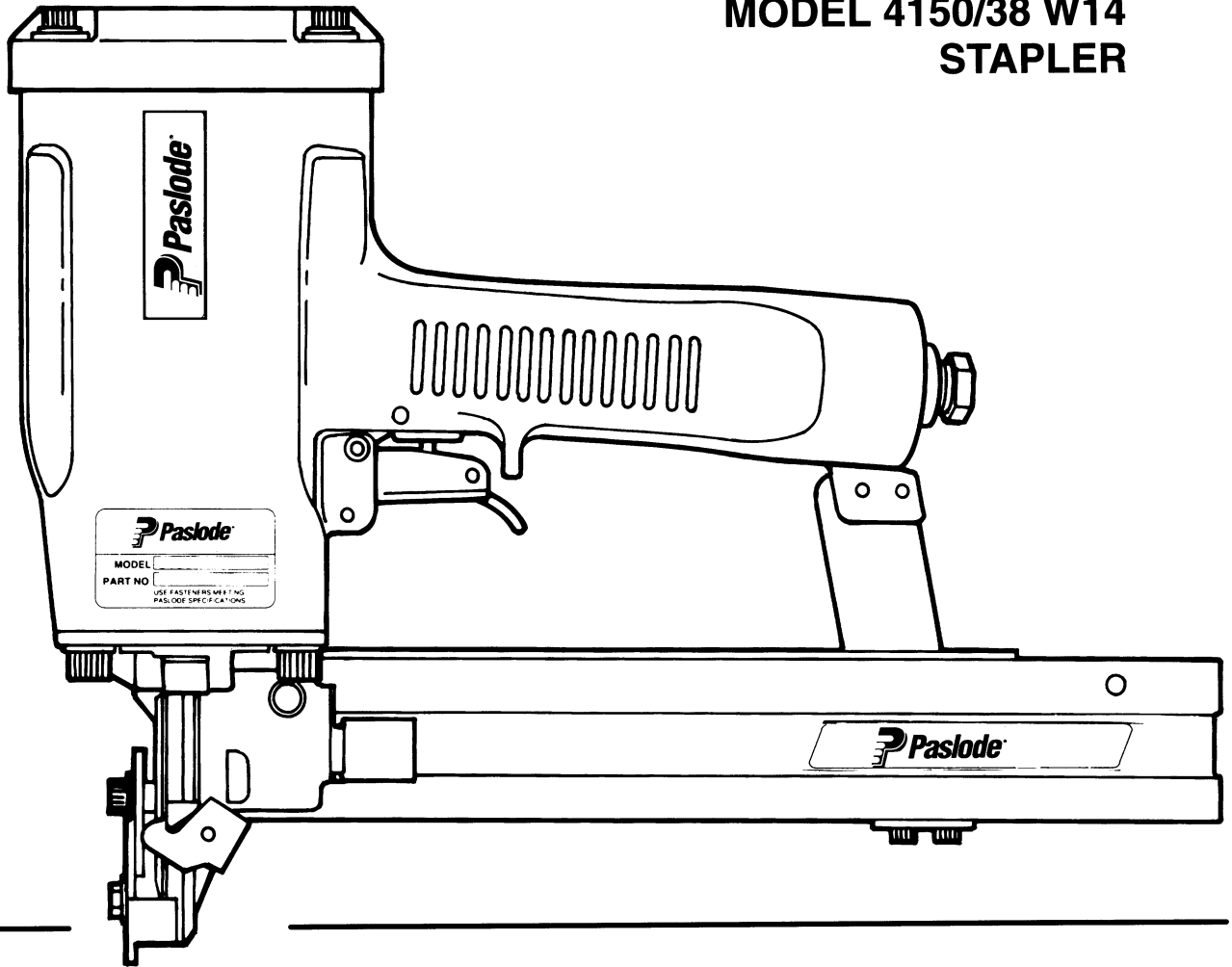

**MODEL 4150/38 W14
STAPLER**



**IMPORTANT!
DO NOT DESTROY**

Always refer to safety and maintenance manual #403606 for detailed information on this tool. It is the customer's responsibility to have all operators and service personnel read and understand this information.

TOOL SCHEMATIC AND PARTS

Model 4150/38 W14, 405194

1	404229	4	S.H.C.S. 1/4-20 x 2-1/4"	47	402983	1	Flange, Nose
→ 2	002187	4	REMOVED	→ 48	095417	4	REMOVED
3	091447	4	Washer	49	009016	4	S.H.C.S. 5/16-18 x 1"
4	402979	4	Spacer, Diffuser	50	004502	4	REMOVED
5	402978	1	Cap, Diffuser	→ 51	004238	4	REMOVED
→ 6	500011	1	Cap	→ 52	092037	2	Lock Nut, 10-32
7	402955	1	Gasket, Cap	→ 53	403716	2	S.H.C.S. 10-32 x 1/4"
8	402959	1	Spring, Main Valve	54	405202	1	Rail Bracket
9	500322	1	Retaining Ring	55	402738	1	Spring
*10	402962	1	O-Ring, Upper Valve Piston	56	402629	1	Hardened Washer
11	402941	1	Upper Valve Piston	57	405200	1	Intermediate W.C.E.
*12	092729	1	O-Ring, Lower Valve Piston	→ 58	402736	1	REMOVED
*13	004163	1	O-Ring, Lower Valve Piston	→ 59	402608	1	REMOVED
*14	402974	1	O-Ring, Lower Valve Piston	→ 60	406039	1	Work Contacting Element
15	500321	1	Lower Valve Piston	61	405203	1	Front Guide
16	405211	1	Seal, Main Valve	62	009037	2	S.H.C.S. 1-32 x 1/2"
*17	402963	1	O-Ring, Main Valve Post	63	405204	1	Back Plate
18	402944	1	Post, Main Valve	64	404698	2	Roll Pin assembly
▲ 19	070502	1	B.H.Mach.S. 8-32 x 5/8"	65	402730	1	Pivot Pin, Front Guide
→ 20	500726	1	Gripco Nut, Special	66	405078	1	Spring, Front Latch
21	095412	1	Washer, Driver Blade	67	402761	1	Latch, Front Guide
*22	091967	1	O-Ring, Piston	68	402762	1	Roll Pin, 5/32 x 1-3/4"
→ 23	500725	1	Piston	→ *69	500459	1	Warning Label
▲ *24	401229	1	Driver Blade	70	402748	1	Pivoting Rail Cover Assembly
25	402954	1	Seal, Sleeve	71	404848	1	Rail & Rail Cover Assembly
→ 26	500583	1	Sleeve	72	402731	1	Logo, Magazine
*27	402961	1	O-Ring, Sleeve	73	402740	1	Roll Pin 3/32 x 7/16"
*28	402728	2	O-Ring, Sleeve	→ 74	070545	1	REMOVED
*29	405197	1	Bumper	▲ 75	091568	1	Binding Hd. Screw, 6-32 x 1/4"
30	500010	1	Sleeve, Bumper	76	091532	1	Negator
31	402079	1	Pin, Trigger	77	091534	1	Drum, Negator
32	404938	2	Logo, Housing	78	402743	1	Pin, Negator Drum
33	402926	1	Housing	79	402759	1	Spring, Follower Latch
34	091622	1	Reducing Pipe Bushing	80	402758	1	Follower Latch
35	097748	1	Spring, Valve Pin	81	402486	1	Retaining Washer
36	097746	1	Valve Pn	82	405201	1	Follower
37	401958	1	Valve Body	83	402668	1	Retaining Ring
38	026133	2	Roll Pin 1/8" x 1"	84	091591	1	O-Ring
*39	092174	1	O-Ring, Valve Body	85	401940	1	End Plug
40	405144	1	Trigger	86	405196	1	Sleeve, Bumper
41	404325	1	Stop Nut	87	405147	1	Lever, Trigger
42	405198	1	Seal, Lower	88	005849	1	Roll Pin
43	094295	1	O-Ring	89	405209	1	Spacer
→ 44	500488	1	Grip, Handle	→ 90	402734	1	Spring, W.C.E.
45	096893	1	Nameplate	→ 91	406010	1	Flange
*46	091208	1	O-Ring, Housing	→ 92	401952	1	O-Ring

* Denotes normal wear items

** Make sure Warning Label (500459) is properly affixed.
Replace if necessary. Label available at no charge
through Service Department.

▲ Apply Loctite 242 (Blue)

→ Denotes New Change

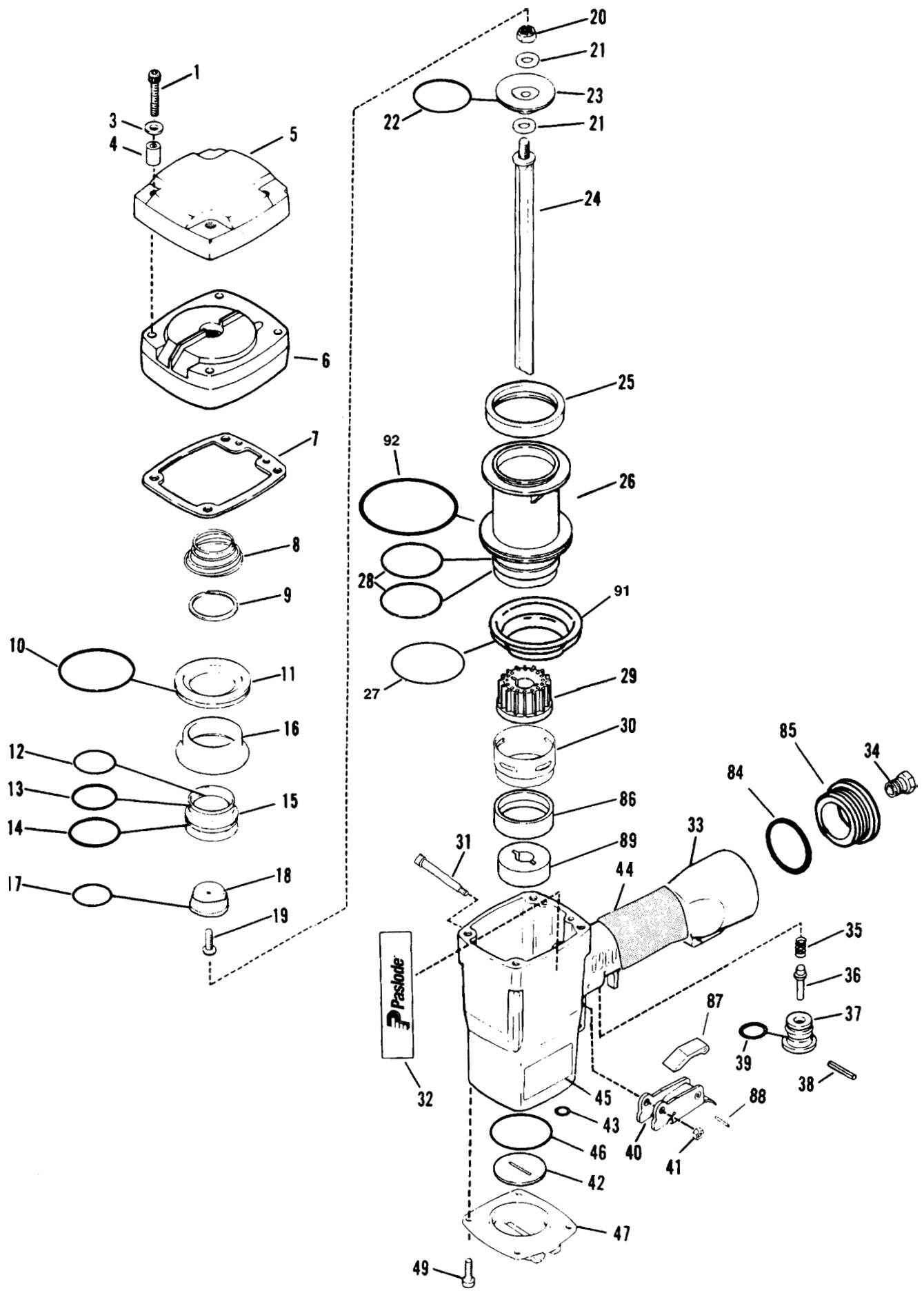

4150/38 W14

405194

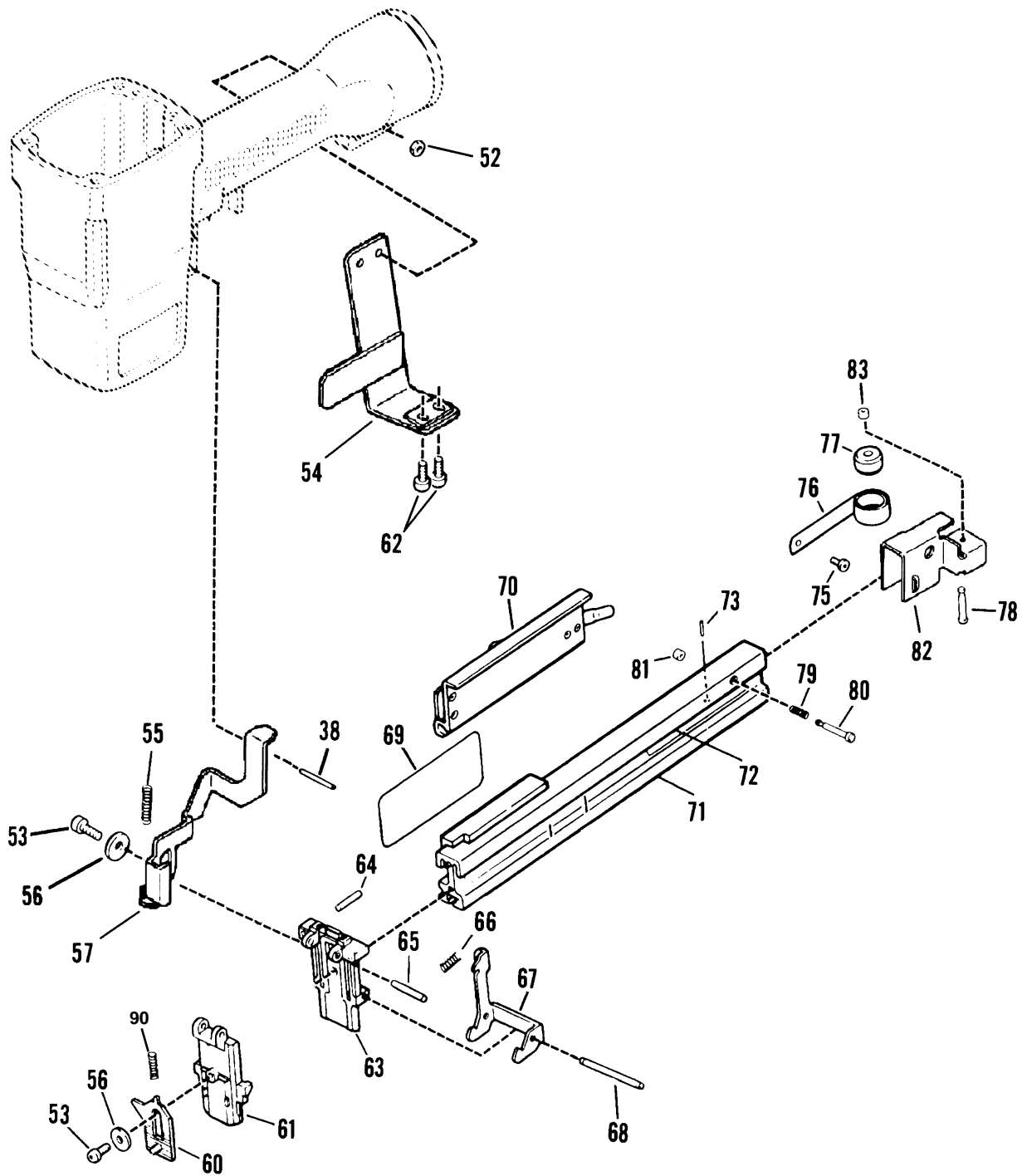

PARTS OFFERED AS ASSEMBLIES

403236 Piston Assembly

Includes

20	500726	1	Gripco Nut, Special
21	095412	2	Washer, Driver Blade
22	091967	1	"O" Ring, Piston
23	500725	1	Piston
24	401229	1	Driver Blade

405212 Main Valve Assembly

Includes

9	500322	1	Retaining Ring
10	402962	1	"O" Ring, Upper Valve Piston
11	402941	1	Upper Valve Piston
12	092729	1	"O" Ring, Lower Valve Piston
13	004163	1	"O" Ring, Lower Valve Piston
14	402974	1	"O" Ring, Lower Valve Piston
15	500321	1	Lower Valve Piston
16	405211	1	Seal, Main Valve

500237 Cap Assembly

Includes

6	500011	1	Cap
8	402959	1	Spring, Main Valve
9	500322	1	Retaining Ring
10	402962	1	"O" Ring, Upper Valve Piston
11	402941	1	Upper Valve Piston
12	092729	1	"O" Ring, Lower Valve Piston
13	004163	1	"O" Ring, Lower Valve Piston
14	402974	1	"O" Ring, Lower Valve Piston
15	500321	1	Lower Valve Piston
16	405211	1	Seal, Main Valve
17	402963	1	"O" Ring, Main Valve Post
18	402944	1	Post, Main Valve
19	070502	1	Button Head Machine Screw #8-32 x 5/8"

402408 Trigger Assembly

Includes

40	405144	1	Trigger
87	405147	1	Lever, Trigger
88	005849	1	Roll Pin

AIR CONSUMPTION CHART

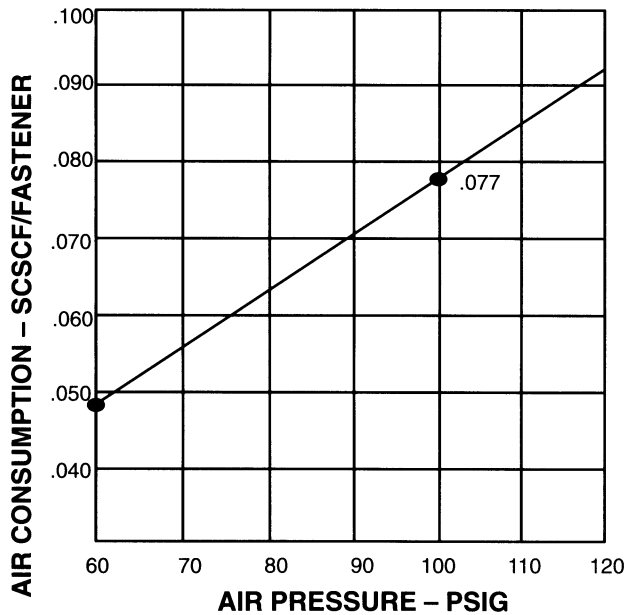

SAFETY INSTRUCTIONS

WEAR EYE AND HEARING PROTECTION



Always wear hearing protection and eye protection devices, including side shields when operating or working in the vicinity of a tool.



DO NOT EXCEED MAXIMUM RECOMMENDED AIR PRESSURE

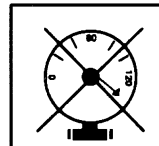

Operate the tool using only the recommended air pressure. Do not exceed the maximum air pressure marked on the tool. Be sure the air pressure gauge is operating properly and check it at least twice a day.

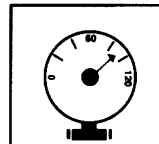

Never use any bottled air or gases such as oxygen to operate the tool since they could cause the tool to explode.

ACCESSORIES

Sequential Operating Kit

This special attachment is designed for sequential operation (stops "contact" firing). The operator must depress and hold the work contacting element against the work surface before pulling the trigger. This sequence must be repeated each time the tool drives a fastener.

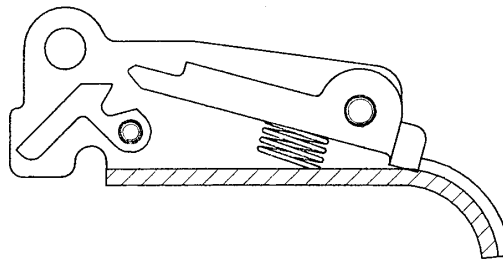

Part No. 406006

Remote Fire Valve

This valve via a positive air signal allows a machine mounted tool to be operated from an automatic air valve or foot pedal system.

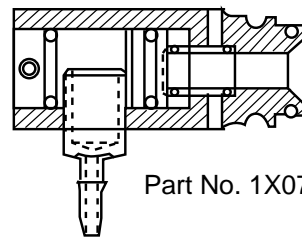

Part No. 1X0713

Lubricants and Loctite

Chemplex 710 Lubricant 1 lb.

Part No. 403734

Lubricating Oil 8 oz.

Part No. 219026

Lubricating Oil 8 oz. with Antifreeze

Part No. 219090

Loctite 242 (Blue) 1 oz.

Part No. 093500

Degreaser Cleaner

Ideal cleaner for all Paslode tools.

Part No. 219086

Belt Hook

Attaches to cap of tool enabling you to carry tool on belt holder (offered below).

Part No. 219017

Belt Hook Holder

Attaches to work belt and carries tool using the above belt hook.

Part No. 219028

Safety Glasses

Clear

Part No. 402510

Tinted

Part No. 402512

Trigger Valve Repair Kit

This kit repairs all trigger valve air leaks.

Part No. 219224

Large Carrying Case

Part No. 219034

