

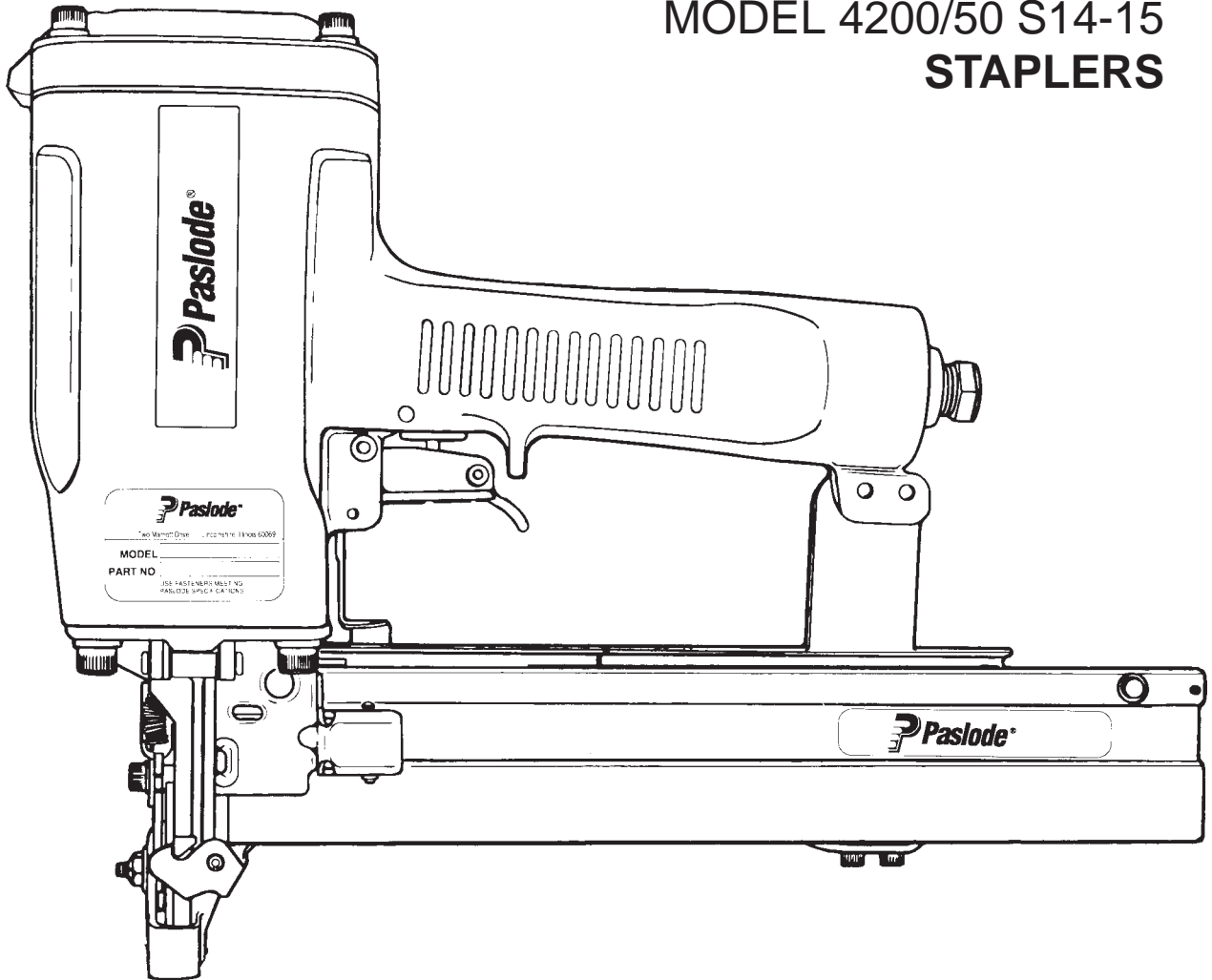

MODEL 4200/50 S16  
MODEL 4200/50 S14-15  
**STAPLERS**



## TOOL SCHEMATIC AND PARTS

**IMPORTANT!**  
**DO NOT DESTROY**

Always refer to safety and maintenance manual #403606 for detailed information on this tool. It is the customer's responsibility to have all operators and service personnel read and understand this information.

**4200/50 S16, 402980**  
**PARTS LEGEND 4200/50 S14-15, 50000**

1	404229	2	Socket Head Capscrew, 1/4-20 x 2-1/4"	49	009016	4	Socket Head Capscrew, 5/16-18 x 1"
3	091447	4	Washer	50	004502	2	Socket Head Capscrew, #10-32 x 5/8"
4	402979	4	Spacer, Diffuser	51	004238	4	Lock Washer, #10
5	402978	1	Cap, Diffuser	52	092037	2	Lock Nut, #10-32
*6	500011	1	Cap	▲ 53	004224	5	Socket Head Capscrew, #10-32 x 3/8"
*7	402955	1	Gasket, Cap	54	402984	1	Rail Bracket
8	402959	1	Spring, Main Valve	*55	402738	2	Spring
9	500322	1	Retaining Ring	56	402629	2	Hardened Washer
*10	402962	1	"O" Ring, Upper Valve Piston	57	402981	1	Intermediate Work Contacting Element
11	402941	1	Upper Valve Piston	58	402736	1	Flat Washer, #10
*12	092729	1	"O" Ring, Lower Valve Piston	59	403207	1	Lower Work Contacting Element
*13	004163	1	"O" Ring, Lower Valve Piston	60	402792	1	Upper Work Contacting Element
*14	402974	1	"O" Ring, Lower Valve Piston	61	403204	1	Front Guide (4200/50 S16)
15	500321	1	Lower Valve Piston		404287	1	Front Guide (4200/50 S14-15)
16	405211	1	Seal, Main Valve	▲ 62	404232	3	Socket Head Capscrew, #8-32x13/16"
*17	402963	1	"O" Ring, Main Valve Post	63	403205	1	Back Plate (4200/50 S16)
18	402944	1	Post, Main Valve		404288	1	Back Plate (4200/50 S14-15)
▲ 19	070502	1	Round Head Machine Screw, #8-32 x 5/8"	64	404698	2	Roll Pin Assembly
20	400196	1	Gripco Nut	65	402730	1	Pivot Pin, Front Guide
21	095412	2	Washer, Driver Blade	66	405079	1	Spring, Front Latch
*22	091967	1	"O" Ring, Piston	67	403206	1	Latch, Front Guide
23	500009	1	Piston	68	092176	1	Roll Pin, 5/32" Dia. x 1-3/8" Lg.
▲ *24	095777	1	Driver Blade	**69	403514	1	Warning Label
25	402954	1	Seal, Sleeve	70	402780	1	Pivoting Rail Cover Assembly
26	406011	1	Sleeve	71	403427	1	Rail and Rail Cover Assembly
*27	402961	1	"O" Ring, Sleeve	72	402731	2	Logo, Magazine
*28	402728	1	"O" Ring, Sleeve	73	402740	1	Roll Pin, 3/32" Dia. x 7/16" Lg.
*29	403762	1	Bumper	74	070545	1	Lock Washer, #6
30	500010	1	Sleeve, Bumper	▲ 75	091568	1	Binding Head Screw, #6-32 x 1/4"
31	402079	1	Pin, Trigger	*76	091532	1	Negator
32	404938	2	Logo, Housing	77	091534	1	Drum, Negator
33	402926	1	Housing	78	402743	1	Pin, Negator Drum
34	091622	1	Reducing Pipe Bushing, 1/4" x 3/8"	79	402799	1	Spring, Follower Latch
35	097748	1	Spring, Valve Pin	80	402798	1	Button, Follower Latch
36	097746	1	Valve Pin	81	402797	1	Bushing, Follower Latch
37	401958	1	Valve Body	82	402796	1	Follower
38	026133	2	Roll Pin, 1/8" Dia. x 1" Lg.	83	402668	1	Retaining Ring
*39	092174	1	"O" Ring, Valve Body	84	091591	1	"O" Ring
40	405144	1	Trigger	85	401940	1	End Plug
41	404325	1	Stop Nut	87	405147	1	Lever, Trigger
42	095778	1	Seal	88	005849	1	Roll Pin
43	094295	1	"O" Ring	89	500488	1	Grip.Handle
45	500690	1	Nameplate (4200/50 S16)	90	403716	2	Socket Head Capscrew 10-32 x 5/16"
	096893	1	Nameplate (4200/50 S14-15)	91	402734	1	Spring
*46	091208	1	"O" Ring Housing	92	406010	1	Flange,Sleeve
47	402983	1	Flange, Nose	93	401952	1	"O" Ring, Fange Sleeve
48	095417	4	Lock Washer, 5/16"				

\* Denotes normal wear items.

\*\* Make sure warning label (403514) is properly affixed.  
 Replace if necessary. Label available at no charge through the Service Dept.

▲ Apply Loctite 242 (Blue) Part No. 093500

➔ Denotes new change.

## PARTS OFFERED AS ASSEMBLIES

### 500176 Piston Assembly

Includes

20	400196	1	Gripco Nut
21	095412	2	Washer, Driver Blade
22	091967	1	"O" Ring, Piston
23	500009	1	Piston
24	096050	1	Driver Blade

### 405212 Main Valve Assembly

Includes

9	500322	1	Retaining Ring
10	402962	1	"O" Ring, Upper Valve Piston
11	402941	1	Upper Valve Piston
12	092729	1	"O" Ring, Lower Valve Piston
13	004163	1	"O" Ring, Lower Valve Piston
14	402974	1	"O" Ring, Lower Valve Piston
15	500321	1	Lower Valve Piston
16	405211	1	Seal, Main Valve

### 500237 Cap Assembly

Includes

4	091363	1	Flexloc Thin Nut, #8-32
5	401955	1	Flat Washer, #8
6	500011	1	Cap
9	500322	1	Retaining Ring
10	402962	1	"O" Ring, Upper Valve Piston
11	402941	1	Upper Valve Piston
12	092729	1	"O" Ring, Lower Valve Piston
13	004163	1	"O" Ring, Lower Valve Piston
14	402974	1	"O" Ring, Lower Valve Piston
15	500321	1	Lower Valve Piston
16	405211	1	Seal, Main Valve
17	402963	1	"O" Ring, Main Valve Post
18	402944	1	Post, Main Valve
19	070502	1	Button Head Socket Cap Screw #8-32 x 5/8"

### 402408 Trigger Assembly

Includes

40	405144	1	Trigger
87	405147	1	Lever
88	005849	1	Roll Pin

## SAFETY INSTRUCTIONS

WEAR EYE AND HEARING PROTECTION



Always wear hearing protection and eye protection devices, including side shields when operating or working in the vicinity of a tool.



DO NOT EXCEED MAXIMUM  
RECOMMENDED AIR PRESSURE

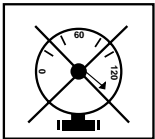

Operate the tool using only the recommended air pressure. Do not exceed the maximum air pressure marked on the tool.

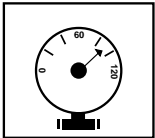

Be sure the air pressure gauge is operating properly and check it at least twice a day.

Never use any bottled air or gases such as oxygen to operate the tool since they could cause the tool to explode.

**AIR CONSUMPTION CHART**

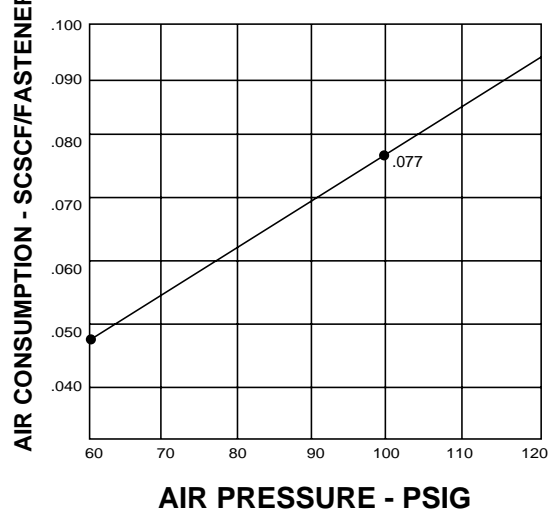

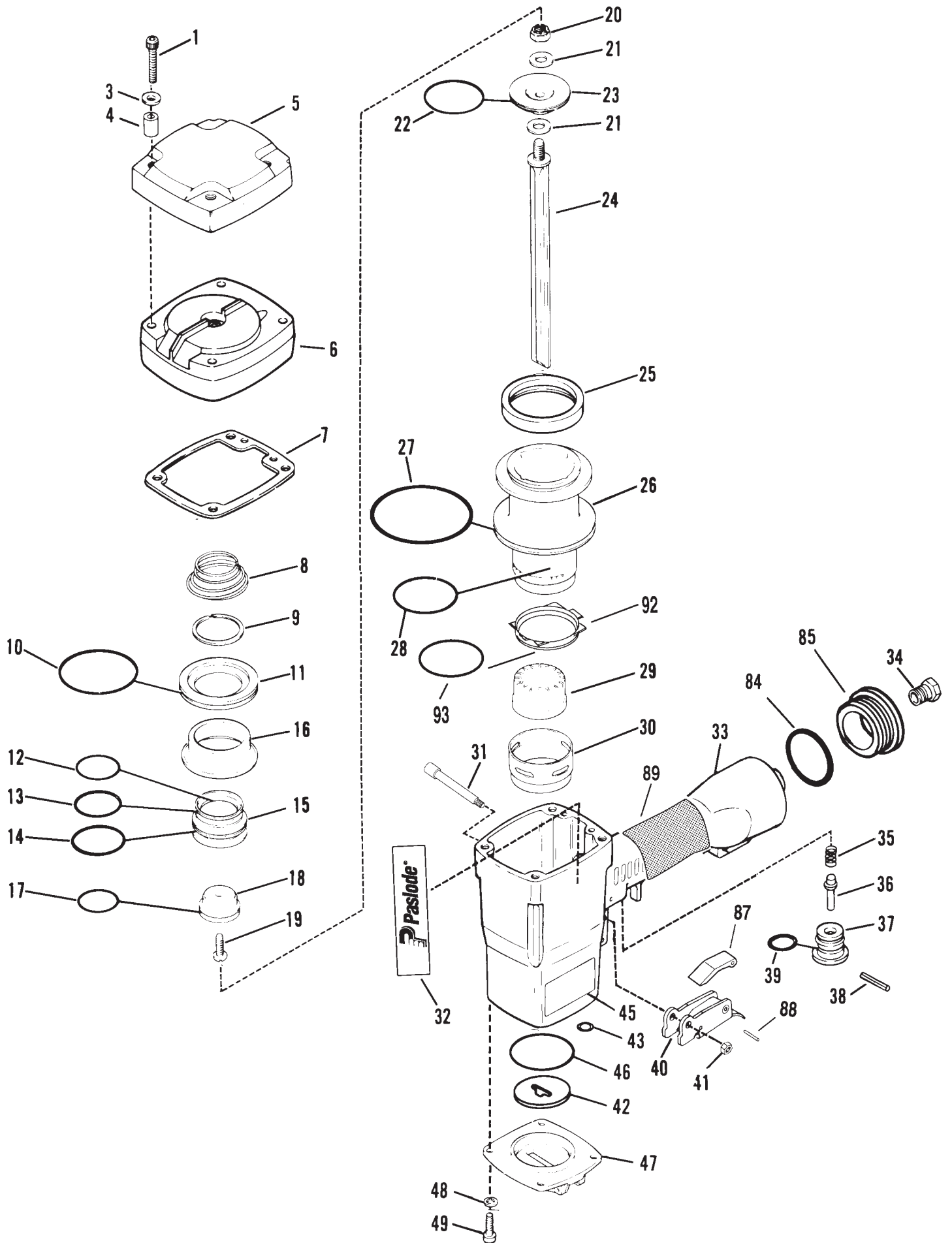



# ACCESSORIES

---

## Sequential Operating Kit

This special attachment is designed for sequential operation (stops "contact" firing). The operator must depress and hold the work contacting element against the work surface before pulling the trigger. This sequence must be repeated each time the tool drives a fastener.

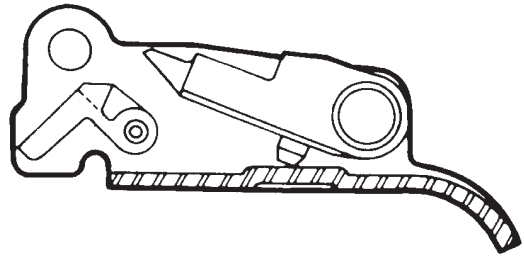

Part No. 406006

---

## Remote Fire Valve

This valve via a positive air signal allows a machine mounted tool to be operated from an automatic air valve or foot pedal system.

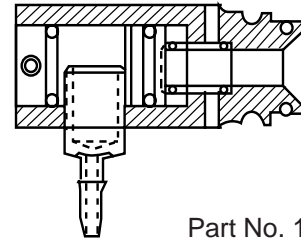

Part No. 1X0713

---

## Lubricants and Loctite

- Loctite 242 (Blue) 1 oz.
- Lubricating Oil 16 oz.
- Lubricating Oil with Antifreeze
- Chemplex 710 Lubricant 1 lb.

Part No. 093500  
Part No. 403720  
Part No. 219090  
Part No. 403734

---

## Degreaser Cleaner

Ideal Cleaner for all Paslode Tools

Part No. 219086

---

## Safety Glasses

- Clear
- Tinted

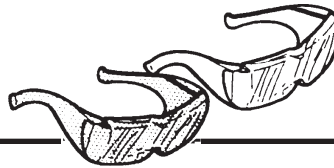

Part No. 402510  
Part No. 402512

---

## Universal Belt Hook

Attaches to cap of tool enabling you to carry tool on belt holder

Part No. 219017

---

## Belt Hook Holder

Attaches to work belt and carries tool using the above belt hook

Part No. 219028

---

## Large Carrying Case

Part No. 219034

---



An Illinois Tool Works Company  
888 Forest Edge Drive  
Vernon Hills, IL 60061