

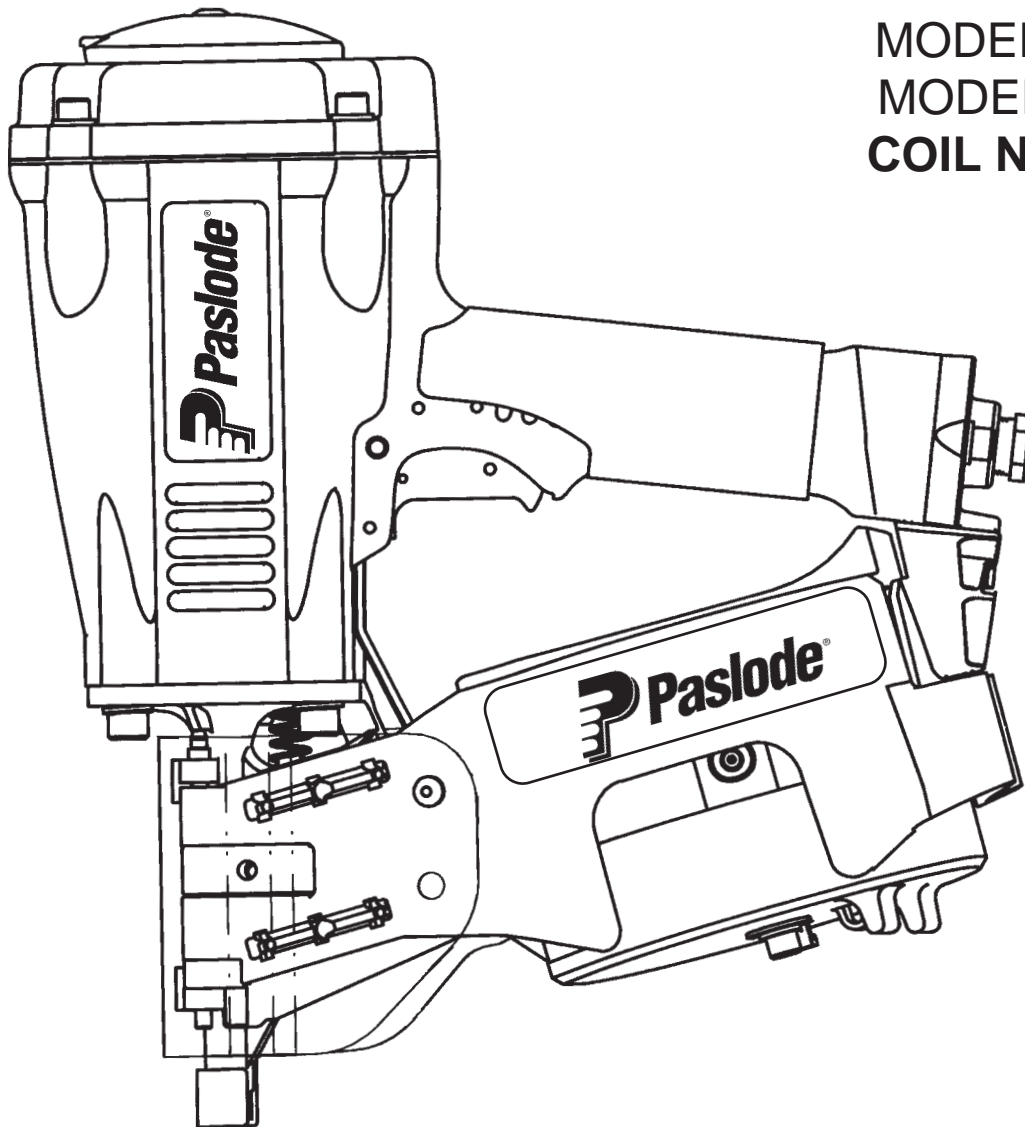

MODEL P275C  
MODEL F275C  
COIL NAILERS



## TOOL SCHEMATIC AND PARTS

**IMPORTANT!**  
**DO NOT DESTROY**

Always refer to safety and maintenance manual #403606 for detailed information on this tool. It is the customer's responsibility to have all operators and service personnel read and understand this information.

# PARTS LEGEND

**P275-C, 500750**

**F275-C, 500760**

▲1	501043	1	T.H.S.C.S. 1/4-20 x 1/2"	39	501008	1	Lever, Bottom Trip
2	501016	1	Air Deflector	40	501010	1	Trigger
3	092735	6	S.H.C.S. 1/4-20 x 1-1/4"	41	402669	1	Pin, Trigger
4	092757	7	Flatwasher 1/4"	42	501009	1	Spirol Pin
5	500661	1	Cap	43	263239	1	Retaining Ring
6	500662	1	Gasket, Cap	44	402018	1	End Cap, Feeder Body
7	500754	1	Spacer, Exhaust	45	402084	1	Bumper, Feed Piston
8	500744	1	Stop, Piston	46	402024	1	Spring, Feed Claw Piston
9	500743	1	Spring, Valve	47	500674	1	Feed Claw Piston
10	500742	1	Seat, Spring	*48	402031	1	O-Ring
*11	091986	1	O-Ring	*49	091541	1	O-Ring
*12	092235	1	O-Ring	50	500802	1	Tray Assembly
→13	500947	1	Piston, Valve	51	500670	1	Nose
→14	500740	1	REMOVED	52	500673	1	Feed Claw
*15	500249	1	O-Ring	53	402668	2	Retaining Washer
*16	091864	1	O-Ring	54	095417	4	Lockwasher
17	500664	1	Sleeve	▲55	009016	4	S.H.C.S. 5/16-18 x 1"
18	500665	1	Flange, Sleeve	56	500677	1	Hinge Pin
*19	500813	1	O-Ring	57	500700	1	Spring, Feed Claw
*20	091023	1	O-Ring	58	402037	1	Holdback
21	500663	1	Piston	59	097748	2	Spring
■*22	402956	1	Driver Blade	60	402486	2	Retaining Washer
*23	500751	1	Bumper	61	500675	1	Locator
24	501023	1	Grip	62	402487	2	Pivot Pin
25	091622	1	Reducing Pipe Bushing	63	500679	1	Magazine
26	500668	1	End Cap	64	091733	2	Flexloc Thin Nut
*27	092042	1	O-Ring	65	005562	1	F.H.S.C.S. 1/4-20 x 5/8"
28	500667	1	Housing	66	500812	1	Nail Label
29	501018	2	Label, Housing	67	009041	1	S.H.C.S. 1/4 x 3/4"
30	404663	1	Spring, W.C.E.	68	500784	1	Nameplate (P275)
▲31	004224	1	S.H.C.S. 10-32 x 3/8"	500789	1	Nameplate (F275)	
32	402666	1	Bushing	69	402938	1	Debris Shield
33	008388	1	Flat Washer #10	70	500678	1	Cover, Magazine
34	500672	1	W.C.E. (P275)	**71	500492	1	Warning Label
	500761	1	Upper W.C.E. (F275)	72	402655	1	Logo, Magazine
35	071297	3	Roll Pin	73	500762	1	Lower W.C.E. (F275)
36	097746	1	Valve Pin	74	092174	1	O-Ring
37	401958	1	Valve Body	75	500199	1	Spring
*38	094295	1	O-Ring	76	500816	1	Lower W.C.E.
				77	500471	1	No-Mar Tip

\*

Denotes normal wear items

\*\*

NOTE: Make sure Warning Label (500492) is properly affixed. Replace if necessary. Label available at no charge through Service Department.

▲

Apply Loctite 242 (Blue) Part No. 093500

■

Apply Loctite 680 (Green) Part No. 219241

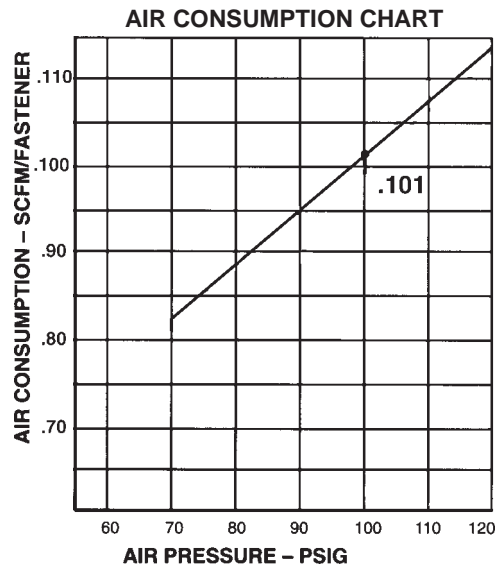

**P275C**  
500750  
**F275C**  
500760

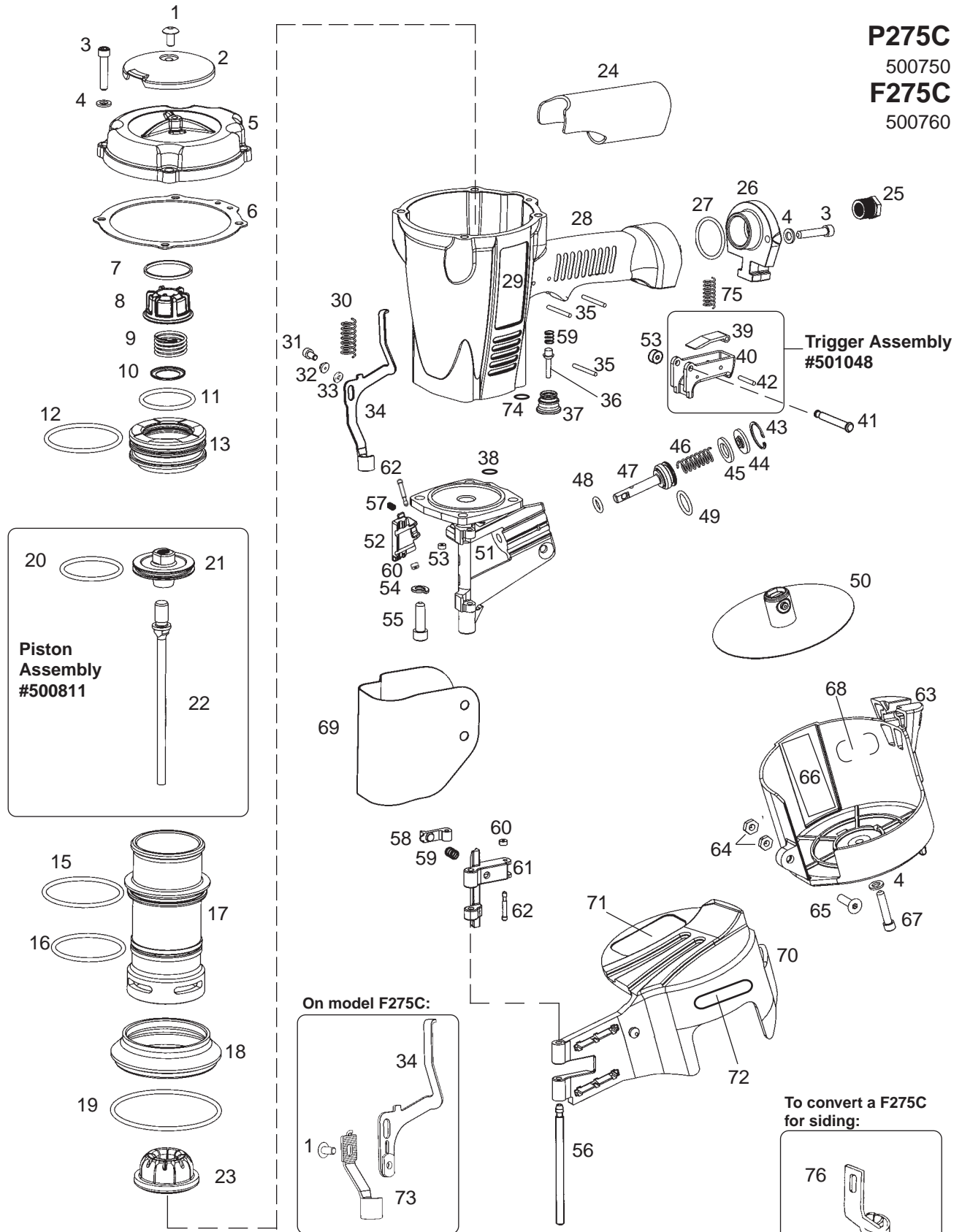

**⚠ WARNING**  
All parts must be periodically inspected and replaced if worn or broken. Failure to do this can affect the tool's operation and present a safety hazard.

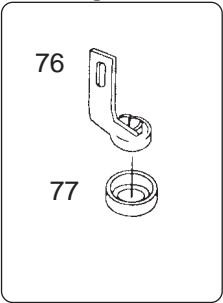

# ACCESSORIES

## Sequential Operating Kit

This special attachment is designed for sequential operation (stops "contact" firing). The operator must depress and hold the work contacting element against the work surface before pulling the trigger. This sequence must be repeated each time the tool drives a fastener.

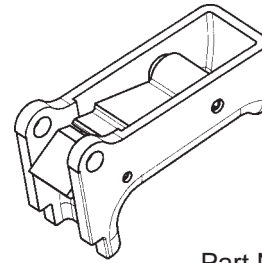

Part No. 501039

## Remote Fire Valve

This valve via a positive air signal allows a machine mounted tool to be operated from an automatic air valve or foot pedal system.

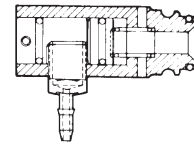

Part No. 1X0713

## Lubricants and Loctite

Loctite 680 (Green)

Part No. 219241

Loctite 242 (Blue) 1 oz.

Part No. 093500

Chemplex 710 Lubricant 1 lb.

Part No. 403734

→ Lubricating Oil 16 oz.

Part No. 403720

Lubricating Oil 8 oz. with Antifreeze

Part No. 219090

## Degreaser Safety Cleaner

Ideal cleaner for all Paslode tools.

Part No. 219086

## Belt Hook/Hanger

Part No. 219239

## Rafter Hook/Hanger

Part No. 219242

## Combination Rafter-Belt/Hanger

Part No. 501073

## Safety Glasses

Clear

Part No. 402510

Tinted

Part No. 402512

## Hex Key - 3/16" (For model F275C only)

For adjusting work contacting element.

Part No. 500783

## → Large Nylon Tool Bag

Part No. 219246

## SAFETY INSTRUCTIONS

### WEAR EYE AND HEARING PROTECTION

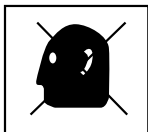

Always wear hearing protection and eye protection devices, including side shields when operating or working in the vicinity of a tool.

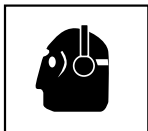

Never use any bottled air or gases such as oxygen to operate the tool since they could cause the tool to explode.

### DO NOT EXCEED MAXIMUM RECOMMENDED AIR PRESSURE

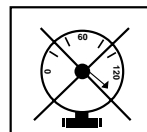

Operate the tool using only the recommended air pressure. Do not exceed the maximum air pressure marked on the tool. Be sure the air pressure gauge is operating properly and check it at least twice a day.

