

description

The Matrix H-66 is a semi-automatic turntable style wrapping machine designed for economical and efficient unitization of pallet loads with stretch film which has been pre-stretched. This machine can dramatically increase throughput rates and lower cost per load compared to manual (hand) stretch wrapping operations

operation

- 1) Place pallet load on turntable with forklift
- 2) Attach film to bottom of load, press start button
- 3) Load is wrapped according to set parameters
- 4) After cycle, cut film and secure tail to load
- 5) Remove wrapped pallet load with forklift

• H-66 features

- Powered prestretch film carriage elongates film 245% (standard)
- Wraps pallet loads up to 55" x 55" x 82"H with auto height sensing
- Load weight capacity up to 4,000 lbs.. (5,000 lb.. with H-66R ring bearing)
- Variable turntable rotation speed with a maximum of 14 RPM
- Forklift portable base design for easy machine transport
- All structural steel construction for years of dependable service
- H-66 features 8-caster DuraGlide™ quiet and reliable turntable support system
- H-66R features 20" diameter precision ring bearing turntable support system
- Non-proprietary replacement parts can be purchased locally or from dealer
- Self-threading Insta-Thread™ carriage makes loading film fast, safe and easy
- Revo-Logic™ technology assures precise number of top/bottom wraps
- Adjustable film roping bar for strong interlocking of load to pallet

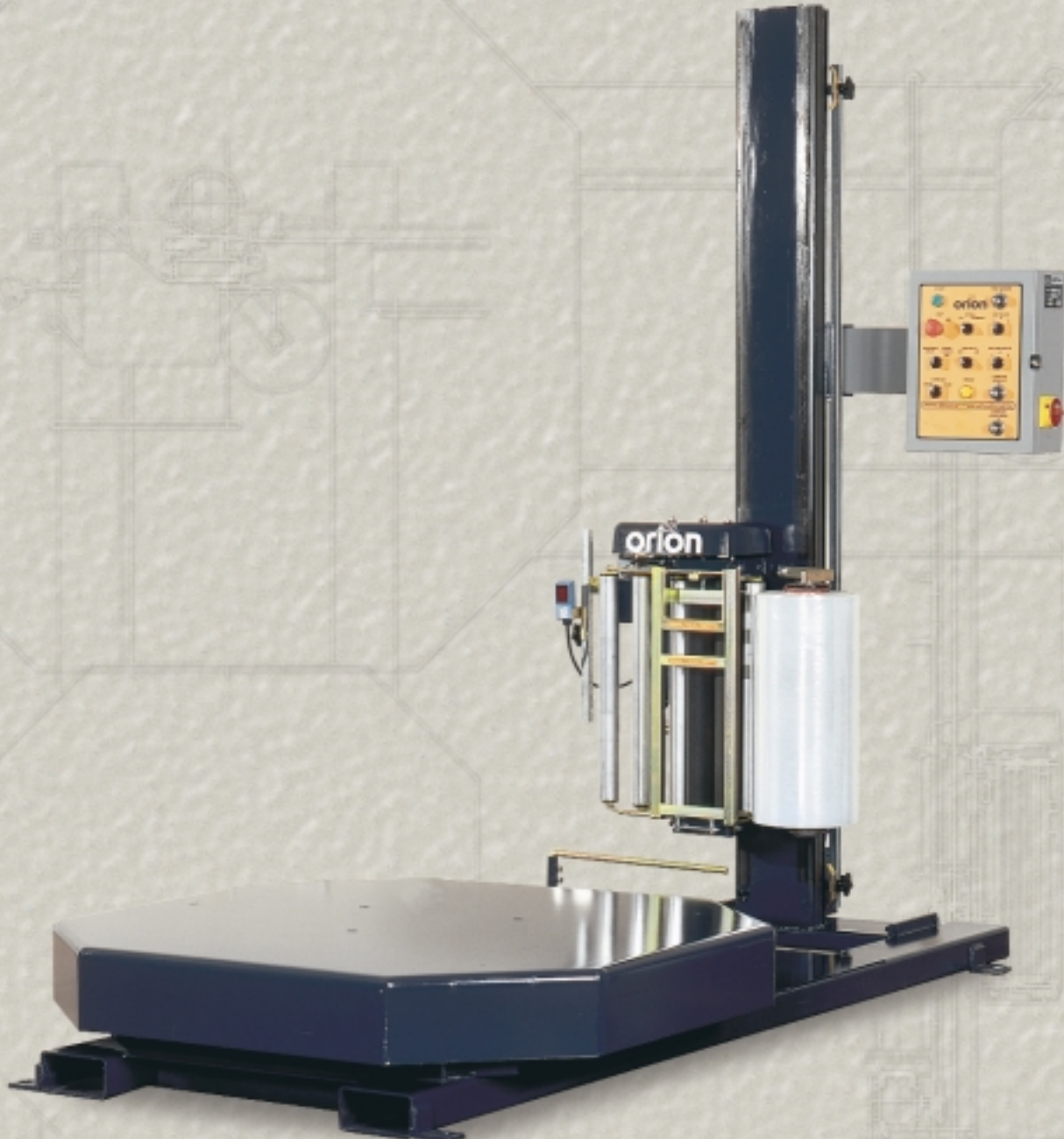

specifications

Machine Performance

Rotation speed Variable to 14 RPM

Film Delivery System

Prestretch ratio 245% (standard)

Threading method Insta-Thread

Corner compensation Electronic

Load Specifications

Maximum load weight 4,000 pounds (H-66)

5,000 pounds (H-66R)

Maximum load size 55"W x 55"L x 82"H

Power Requirements

115 / 1 / 60 15 amp

Structural Design

100% Structural steel used throughout

Portable after initial installation

Structural steel tube mast

Warranty

3/5 Year limited

Estimated Shipping Weight

H-66: 1,200 pounds

H-66R: 1,300 pounds

dimensions

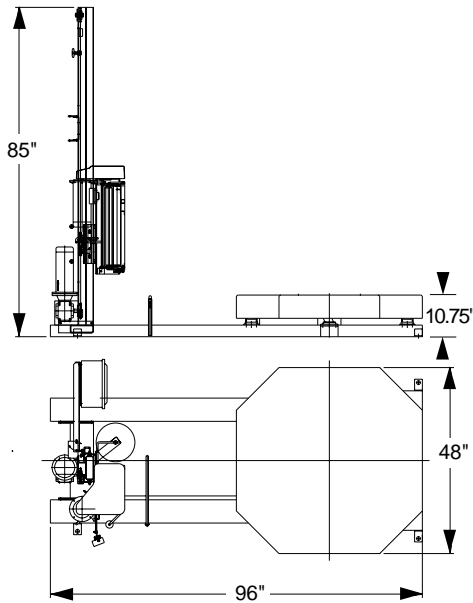

Insta-Thread™ Film Delivery System: Fast, Easy, Consistent

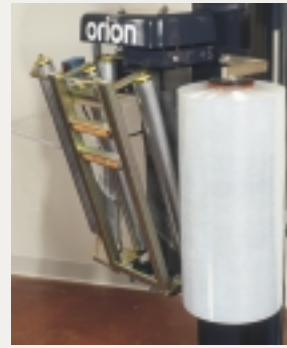

Threading the Insta-Thread film carriage is fast and easy: simply open the hinged roller frame, pull the film across, then close and latch the frame. It's fast, safe and easy.

The H-66 and H-66R use the Insta-Thread™ film delivery system, an extremely reliable film carriage engineered to accurately pre-stretch film at a fixed rate of 245% and deliver it to the load at a constant tension level. Higher or lower rates are available optionally.

- Uses standard 20" stretch film rolls
- Precision ground, polyurethane pre-stretch rollers for consistent, maximum film yield
- 245% standard pre-stretch ratio for best economy
- Carriage lifted by heavy-duty ANSI industrial chain
- Electronic film tension control on control panel
- Variable speed film output for even tension on corners
- Heavy-duty ANSI chain & sprocket ratio control
- Multi-point UHMW precision carriage guidance system
- Revo-Logic™ exact wrap count technology eliminates film waste by applying top & bottom wraps precisely

Controller: Non-proprietary, Easy to Use, UL, NEMA-12



- CSA Approved, UL listed, NEMA 12 controller
- Non-proprietary pushbuttons and switches
- Large mushroom-style Emergency E-Stop button
- Electronic film tension control on keypad
- State-of-the-art Allen Bradley MicroLogix PLC
- Separate settings for top wraps & bottom wraps
- Separate speed settings for carriage up & down
- Raise & lower carriage manually with Carriage Jog
- Pause wrap cycle without resetting with Cycle Pause
- Rotate turntable manually with Turntable Jog
- Wrap Up Only key for uni-directional wrap mode

Turntable Drive & Support: Quiet, Easy to Maintain



- Direct heavy-duty ANSI chain & sprocket drive
- Quiet & durable Dura-Glide™ turntable support
- Variable speed drive motor: 0-14 RPM
- Positive home position alignment puts turntable in same position after each wrap cycle
- Steel baffles prevent accidental forklift damage
- All components easily accessible for service
- Electronically adjustable soft start (gradual turntable acceleration)

H-66R Ring Bearing Turntable Support

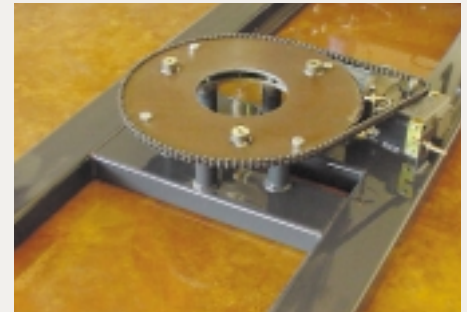

- 20" precision ring bearing turntable support
- 5,000 pound weight capacity for heavier loads
- Quiet, reliable, maintenance-free

distributed by:



Orion Packaging Systems, Inc.
A Pro Mach Operating Partner
USA Corporate Headquarters
100 Crescent Drive
Collierville, TN 38017
Toll Free (800) 333-6556
Telephone (901) 888-4170
Fax (901) 365-1071

CANADA Manufacturing
2270 Industrial Blvd
Laval, Montreal, H7S 1P9
Telephone (450) 667-9769
Fax (450) 667-6320

Email: sales@orionpackaging.com
Web: www.orionpackaging.com
Bulletin #H66.03/01.JKG

All dimensions approximate. Orion Packaging Systems reserves the right to change specifications without notice.