

description

The Matrix L-55S is a heavy-duty semi-automatic turntable style wrapping machines designed for economical and efficient unitization of pallet loads with stretch film which has been pre-stretched. This machine can dramatically increase throughput rates and lower cost per load compared to manual (hand) stretch wrapping operations.

operation

- 1) Place load on turntable with forklift or pallet jack
- 2) Attach film to bottom of load, press start button
- 3) Load is wrapped according to set parameters
- 4) After cycle, cut film and secure tail to load
- 5) Remove wrapped pallet load

• L-55S features

- Powered prestretch film carriage elongates film 245% (standard)
- Wraps pallet loads (60" x 60" max.) weighing up to 6,000 pounds
- Automatically adjusts for various load heights (up to 84" maximum)
- Variable turntable rotation speed with a maximum of 16 RPM
- Forklift portable base design for easy machine transport
- All structural steel construction for years of dependable service
- 15-caster DuraGlide™ turntable support system is quiet and maintenance-free
- Non-proprietary replacement parts can be purchased locally or from dealer
- Self-threading Insta-Thread™ carriage makes loading film fast, safe and easy
- Revo-Logic™ technology assures precise number of top/bottom wraps
- Adjustable film roping bar for strong interlocking of load to pallet
- Full steel surrounding base frame for easy loading with electric walkie or pallet jack

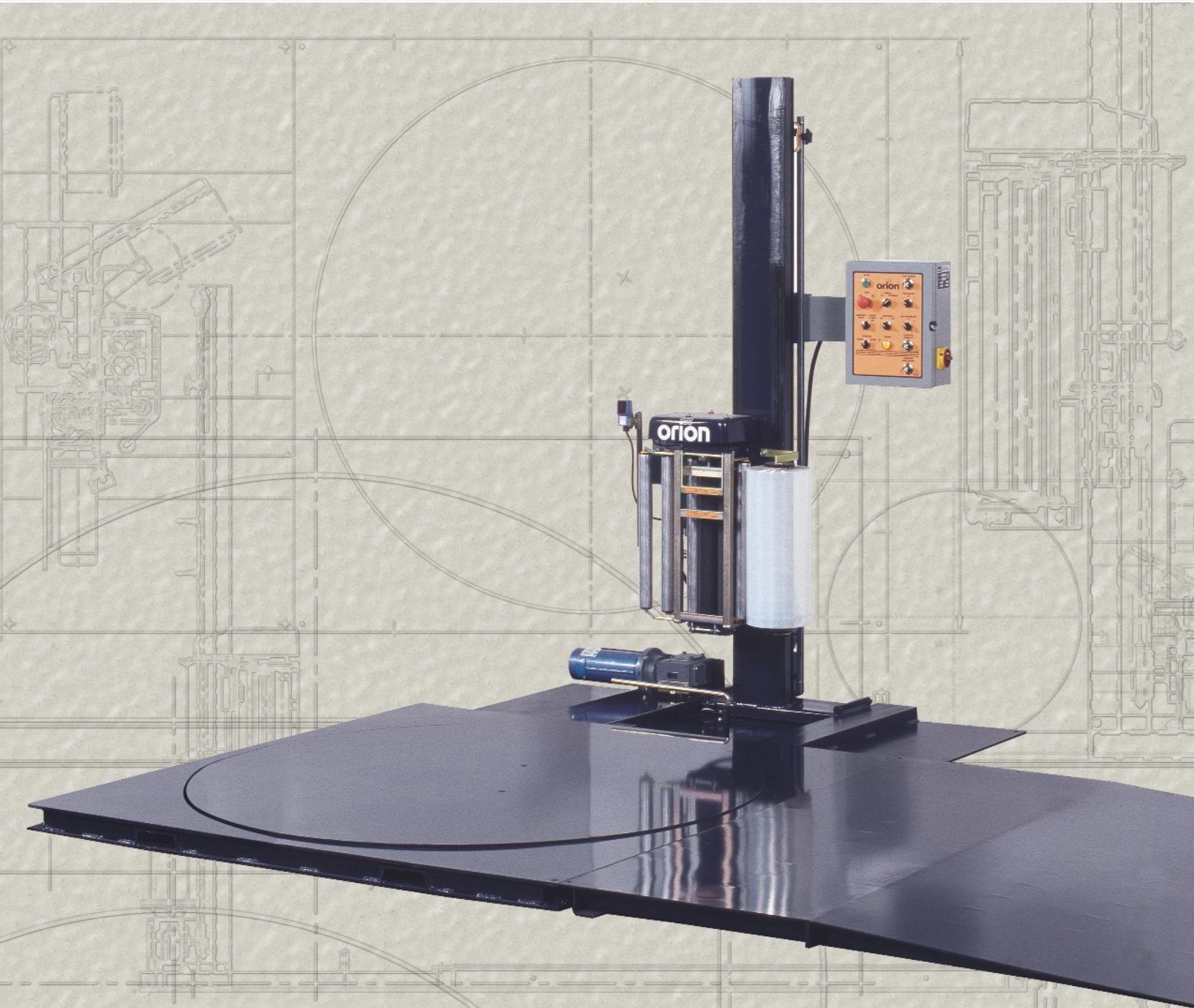

specifications

Machine Performance

Rotation speed Variable to 16 RPM

Film Delivery System

Prestretch ratio 245% (standard)
Threading method Insta-Thread
Corner compensation Electronic

Load Specifications

Maximum load weight 6,000 pounds
30,000 pounds static
Maximum load size 60"W x 60"L
Maximum load height 84"

Power Requirements

115 / 1 / 60 15 amp

Structural Design

100% Structural steel used throughout
Portable after initial installation
Structural steel tube mast

Warranty

3/5 Year limited

Estimated Shipping Weight

2,200 pounds

dimensions

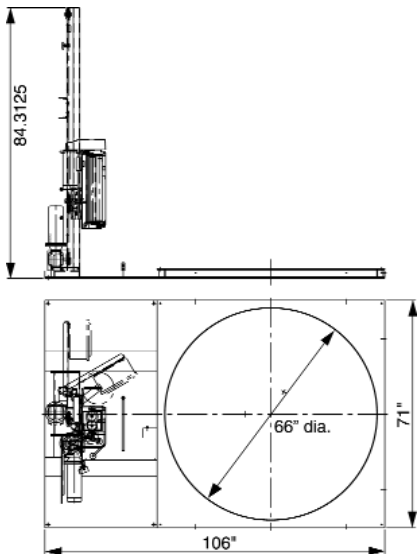

The 'open' design of the Orion L-55S means that major components such as motors and gearboxes are within easy reach for fast and convenient maintenance or repair.

Insta-Thread™ Film Delivery System: High Performance, Consistent, Easy to Thread



Threading the Insta-Thread film carriage is fast and easy: simply open the hinged roller frame, pull the film across, then close and latch the frame. It's fast, safe and easy.

The L-55S uses the Insta-Thread™ film delivery system, an extremely reliable film carriage engineered to accurately pre-stretch film at a fixed rate of 245% and deliver it to the load at a constant tension level. Higher or lower rates are available optionally.

- Variable speed film output for even film tension on both the flat sides and corners of load
- Heavy-duty ANSI chain & sprocket ratio control
- Multi-point UHMW precision carriage guidance
- Revo-Logic™ exact wrap count technology eliminates film waste by applying top & bottom wraps precisely
- Uses standard 20" stretch film rolls
- Precision ground, polyurethane pre-stretch rollers for consistent, maximum film yield
- 245% standard pre-stretch ratio for best economy
- Carriage lifted by heavy-duty ANSI industrial chain
- Electronic film tension control on control panel

Controller: Non-proprietary, Easy to Use, UL, NEMA-12



- CSA Approved, UL listed, NEMA 12 controller
- Non-proprietary pushbuttons and switches
- Large mushroom-style Emergency E-Stop button
- Electronic film tension control on keypad
- State-of-the-art Allen Bradley MicroLogix PLC
- Separate settings for top wraps & bottom wraps
- Separate speed settings for carriage up & down
- Raise & lower carriage manually with Carriage Jog
- Pause wrap cycle without resetting with Cycle Pause
- Rotate turntable manually with Turntable Jog
- Wrap Up Only key for uni-directional wrap mode
- End-of-cycle film force release reduces motor wear

Turntable Drive & Support: Quiet, Easy to Maintain



Maintenance or replacement of a Dura-Glide caster is fast and easy. The self-aligning casters are made from a compressed synthetic material for long life and quiet operation.

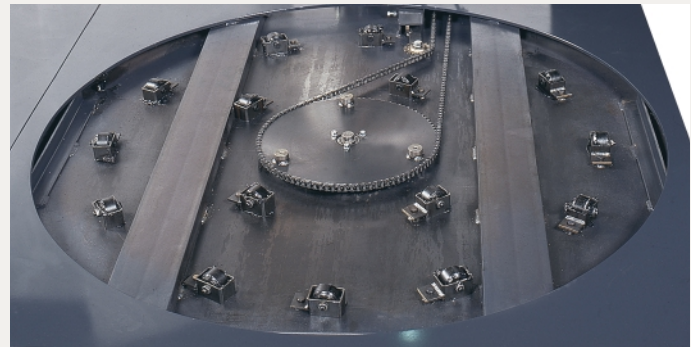

Loads weighing up to 6,000 pounds are supported by Orion's Dura-Glide support system

distributed by:



Orion Packaging Systems, Inc.
A Pro Mach Operating Partner
USA Corporate Headquarters
100 Crescent Drive
Collierville, TN 38017
Toll Free (800) 333-6556
Telephone (901) 888-4170
Fax (901) 365-1071
CANADA Manufacturing
2270 Industrial Blvd
Laval, Montreal, H7S 1P9
Telephone (450) 667-9769
Fax (450) 667-6320
Email: sales@orionpackaging.com
Web: www.orionpackaging.com
Bulletin #L55S.10/01.JKG

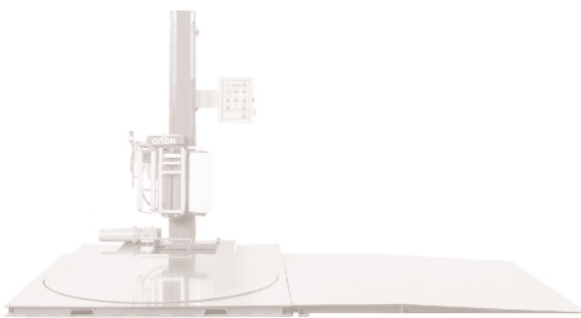

- Heavy-duty chain drive with tensioner
- Quiet & durable Dura-Glide™ turntable support
- Variable speed drive motor: 0-16 RPM
- Positive home position alignment puts turntable in the same position after each wrap cycle
- Many non-proprietary replacement parts
- All components easily accessible
- Electronically adjustable soft start and stop (gradual turntable acceleration and deceleration)