

# Framing and Sheathing Nailers

## FramePro® 700E-XL/750E-XL with Think Trac

*Built for X-Tended Life for the high-volume pro.*



### Benefits

- Two year warranty
- Rugged internal design for "X-tended Life"
- ThinkTrac powered by 4 AAA batteries
- Batteries and electronics are water and shock resistant
- Depth-of-drive control and EZ-Clear

### Applications

Framing, Truss Building, Subflooring, Decking, Sheathing, Siding, Fencing, Pallets, Crate Assembly

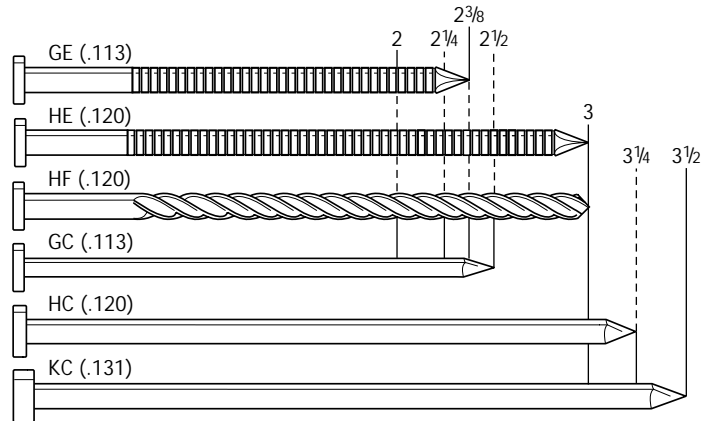

9, 10 1/4, 11 and 11 1/2 Gauge. Clipped-Head Nails. 2" - 3 1/2" 6d - 16d. Smooth, Ring & Screw. Capacity 56 - 80.

## FramePro® 600E with Think Trac

*Productivity without sacrificing safety.*



### Benefits

- ThinkTrac powered by 4 AAA batteries
- Batteries and electronics are water and shock resistant
- Depth-of-drive control and EZ-Clear
- Aggressive sawtooth safety that really digs in for toenailing

### Applications

Framing, Truss Building, Subflooring, Decking, Sheathing, Siding, Fencing, Pallets, Crate Assembly

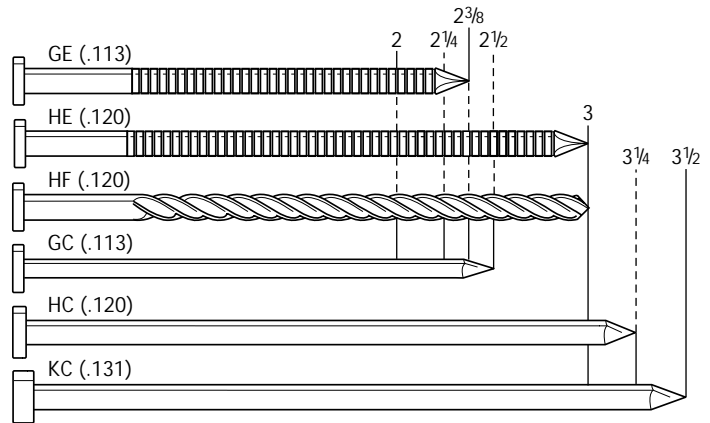

9, 10 1/4, 11 and 11 1/2 Gauge. Clipped-Head Nails. 2" - 3 1/2" 6d - 16d. Smooth, Ring & Screw. Capacity 56 - 80.

# Framing and Sheathing Nailers

## FramePro® 700XL/750XL

FramePro® 700XL: H: 13¼" L: 15" W: 8.0 lbs FramePro® 750XL: H: 14¼" L: 15" W: 8.4 lbs

Built for X-Tended Life for the high volume pro.



### Benefits

- Two-Year Warranty
- Rugged internal engine design for "X-Tended Life"
- Drives a wide variety of clipped head nails from 2" – 3½"
- Lightweight at 8.0 lbs. (750XL: 8.4 lbs)
- Improved comfort grip
- Aggressive toenail safety

### Applications

Framing, Truss Building, Subflooring, Decking, Sheathing, Fencing, Pallets and Crate Assembly, Wood-to-Green Concrete

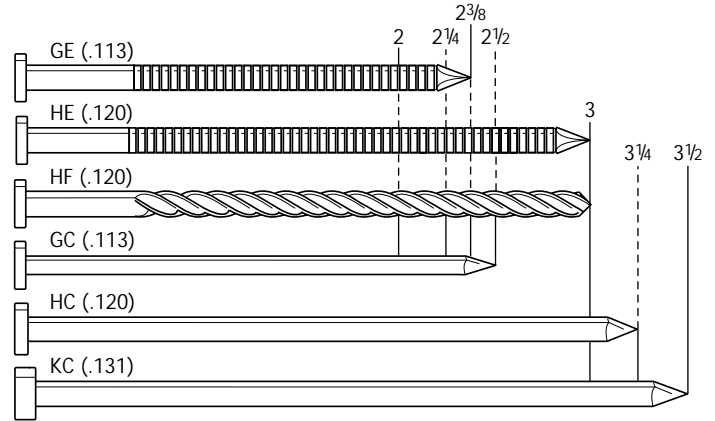

9, 10¼, 11 and 11½ Gauge. Clipped-Head Nails. 2" - 3½" 6d - 16d. Smooth, Ring & Screw. Capacity 56 - 80.

## FramePro® 600/650

FramePro® 600: H: 13¼" L: 15" W: 8.0 lbs FramePro® 650: H: 14¼" L: 15" W: 8.4 lbs

Award-winning clipped head nailers.



### Benefits

- Adjustable depth-of-drive drives nails to a consistent and controllable depth
- Rugged 35° angled magazine easily reaches tight work areas
- Fast cycle time means higher productivity

### Applications

Framing, Truss Building, Subflooring, Decking, Sheathing, Fencing, Pallets and Crate Assembly, Wood-to-Green Concrete

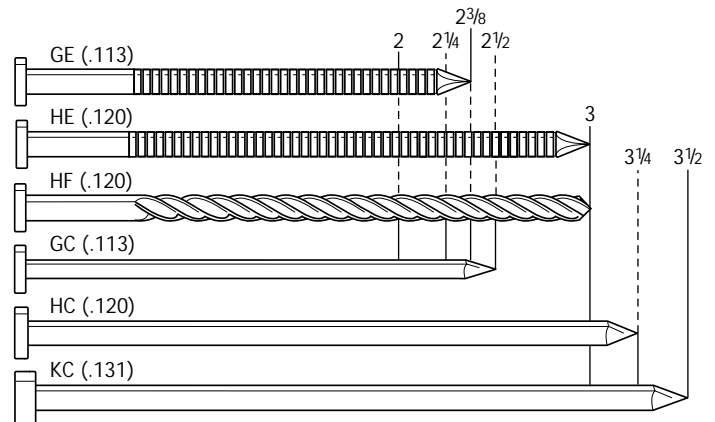

9, 10¼, 11 and 11½ Gauge. Clipped-Head Nails. 2" - 3½" 6d - 16d. Smooth, Ring & Screw. Capacity 56 - 80.

## SN70

H: 14¼" L: 15½" W: 9.7 lbs

The SN70 is the most powerful tool in the line.



\*A modified SN70 drives the 20d, KC31 smooth-shank 4"



### Benefits

- Drives ring, screw and smooth shank nails in lengths from 2" through 3½"
- 30° magazine permits maximum maneuverability in tight work areas
- Drives 2¼" hardened steel nails into concrete

### Applications

Framing, Trusses, Subflooring, Decking, Sidewall Sheathing, Roof Decks, Heavy-Duty Pallets, Crate and Box Assembly, Wood-to-Green Concrete

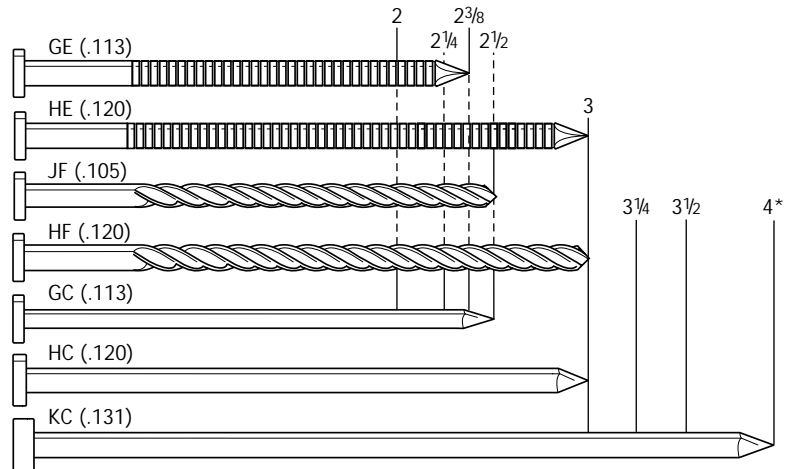

10¼, 11, 11½ and 12 Gauge. Clipped-Head Nails. 2" - 3½" 6d - 16d. Smooth, Ring & Screw. Capacity 50 - 70.

# Framing and Sheathing Nailers

## FramePro® 700XL FRH/750XL FRH 700XL FRH: H: 13¼" L: 20" W: 8.4 lbs 750XL FRH: H: 14¼" L: 20" W: 8.75 lbs

Built for *X-Tended Life* for the high volume pro.

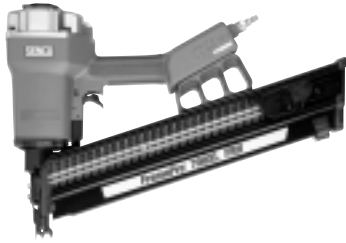

### Benefits

- Two-Year Warranty
- Rugged internal engine design for "X-tended Life"
- Aggressive sawtooth safety that really digs in for toenailing
- In-line magazine for superior balance and line of sight
- Depth-of-Drive control and EZ-Clear feature

### Applications

Framing, Truss building, Subflooring, Sheathing, Decking, Siding, Fencing, Pallets and Crate Assembly.

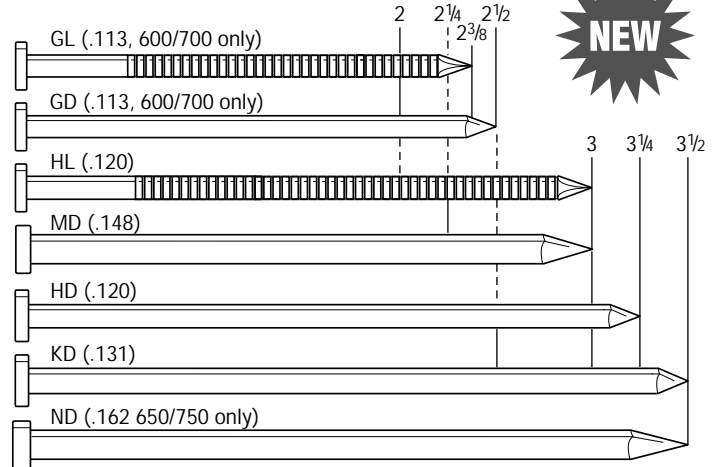

FramePro® 700XL FRH nailer drives 2"–3½" smooth shank nails (Sencote® or plain) and 2"–3" ring shank nails. Shank diameter includes .113, .120, .131 and .148.

FramePro® 750XL FRH nailer drives 2¼"–3½" smooth shank nails (Sencote® or plain) and 3" ring shank nails. Shank diameter includes .120, .131, .148 and .162 (Common Nails).

## FramePro® 600 FRH/650 FRH FramePro® 600 FRH: H: 13¼" L: 20" W: 8.4 lbs FramePro® 650 FRH: H: 14¼" L: 20" W: 8.75 lbs

The result of our award-winning, feature loaded clipped head nailers now designed for Full Round Head nails.

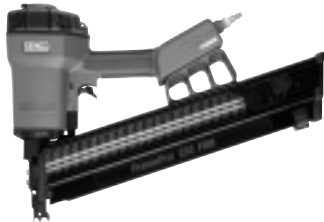

### Benefits

- Aggressive sawtooth safety that really digs in for toenailing
- In-line magazine for superior balance and line of sight
- Depth-of-Drive control and EZ-Clear feature

### Applications

Framing, Truss building, Subflooring, Sheathing, Decking, Siding, Fencing, Pallets and Crate Assembly.

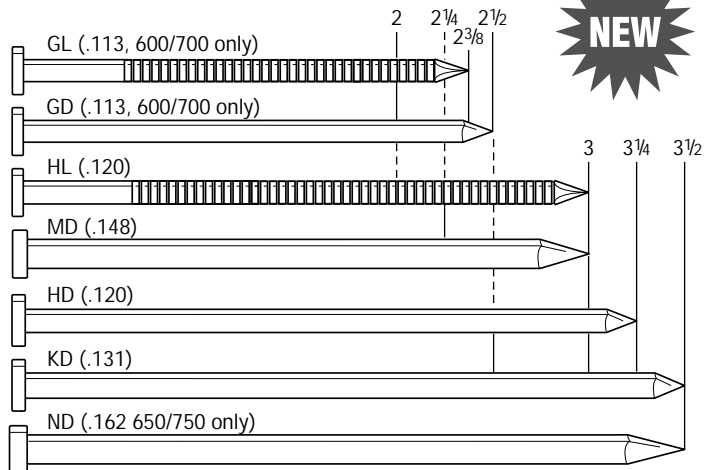

FramePro® 600 FRH nailer drives 2"–3½" smooth shank nails (Sencote® or plain) and 2"–3" ring shank nails. Shank diameter includes .113, .120, .131 and .148.

FramePro® 650 FRH nailer drives 2¼"–3½" smooth shank nails (Sencote® or plain) and 3" ring shank nails. Shank diameter includes .120, .131, .148 and .162 (Common Nails).

# Coil Nailers

**SCN40R** H: 10 $\frac{3}{8}$ " L: 9 $\frac{3}{4}$ " W: 5.2 lbs

Roofing coil nailer designed with a "jaws" configuration to drive nails consistently straight and prevent tumbling of shorter nails.



### Benefits

- Lightweight — 5.2 lbs for easy one-handed operation, improving productivity
- Adjustable depth-of-drive control on the tool means no compressor adjustments or additional tools for adjustments are required
- Neverlube™ Design — requires no lubrication

### Applications

Asphalt and Fiberglass Shingles, Waterproof Tar Paper, Metal Drip Edges, Insulative Sheathing, Upholstery Panels, Siding, Cement Board, Roofing, Roofing Felt

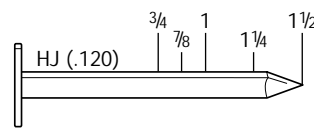

11 Gauge. Full Round-Head Roofing Nails.  $\frac{3}{4}$ " - 1 $\frac{1}{2}$ " 1d - 4d. Smooth. Capacity 120.

**SCN40DW** H: 10 $\frac{3}{8}$ " L: 9 $\frac{3}{4}$ " W: 4.7 lbs

New drywall nailer speeds drywall installation.



### Benefits

- Lightweight — 4.7 lbs for easy one-handed operation, improving productivity
- Adjustable depth-of-drive control on the tool means no compressor adjustments or additional tools for adjustments are required
- Neverlube™ Design — requires no lubrication

### Applications

Drywall Installation



12 $\frac{1}{2}$  Gauge. Full Round Bugle-Head Nails. 1 $\frac{1}{2}$ "-1 $\frac{5}{8}$ " 4d-5d Ring. Capacity 120.

**SCN45** H: 10 $\frac{3}{8}$ " L: 11" W: 4.4 lbs

Tough, reliable tool for box and crate assembly.



### Benefits

- High nail capacity maximizes productivity
- Lightweight at 4.4 lbs for easy handling and excellent maneuverability

### Applications

Pallets, Boxes and Crates, Displays, Sheathing, Fencing, Decking, Subflooring

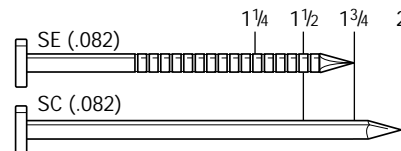

13 $\frac{3}{4}$  Gauge. Flat Round-Head Nails. 1 $\frac{1}{4}$ " - 2" 3d - 6d. Smooth and Ring. Capacity 400.

**SCN55S** H: 12 $\frac{1}{8}$ " L: 10 $\frac{1}{2}$ " W: 5.8 lbs

Lightweight, high-loading choice of wood siding installers.



### Benefits

- At 5.8 lbs, its excellent balance makes for easy one-handed operation
- Adjustable depth-of-drive allows for precise countersinking at a lower air pressure
- Dual collation allows the choice of wire or plastic

### Applications

Siding, Sheathing, Decking, Subflooring, Exterior Trim, Fencing, Wood Shingles

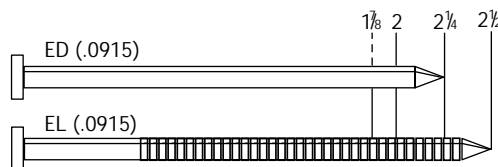

13 and 13 $\frac{3}{4}$  Gauge. Full Round-Head Nails. 1 $\frac{7}{8}$ " - 2 $\frac{1}{2}$ " 5d - 8d. Capacity 350.

## SCN60 H: 12<sup>3</sup>/<sub>8</sub>" L: 12<sup>7</sup>/<sub>8</sub>" W: 7.5 lbs

Lightweight, well-balanced nailer combines maneuverability with fast cycling time for an efficient, easy-to-handle tool.



### Benefits

- Highest power-to-weight ratio in its class
- Light enough for one-handed operation for quality workmanship and greater productivity
- Adjustable depth-of-drive allows for precise countersinking at a lower air pressure

### Applications

Pallets/Pallet Repair, Crate and Box Assembly, Sheathing, Decking, Subflooring, Exterior Decks

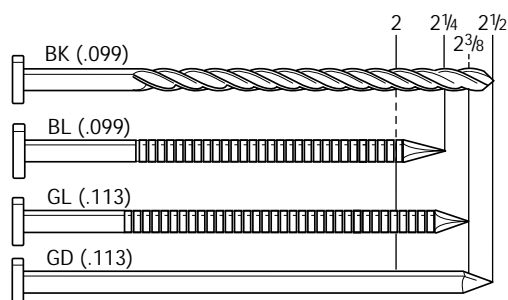

11, 11<sup>1</sup>/<sub>2</sub> and 12<sup>1</sup>/<sub>2</sub> Gauge. Round-Head Nails. 2 - 2<sup>3</sup>/<sub>4</sub>" 6d - 9d Nail Range. Capacity 250 - 275.

## SCN65 H: 14<sup>1</sup>/<sub>8</sub>" L: 12<sup>7</sup>/<sub>8</sub>" W: 8.0 lbs

Rugged, powerful nailer built for increased framing and sheathing productivity with one-handed operation, EZ-Load and fast cycle



### Benefits

- Highest power-to-weight ratio in its class
- Lightweight and ergonomically designed for superb balance and operator comfort
- Adjustable depth-of-drive allows for precise countersinking at a lower air pressure

### Applications

High Production Framing, Sheathing, Decking, Subflooring, Exterior Decks, Pallets/Pallet Repair

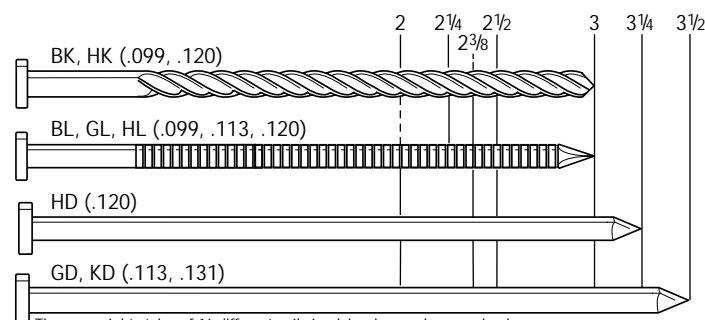

There are eight styles of 16 different nails in plain, ring, and screw shanks.

Drives the nails listed above for SCN60 in addition to these nails:  
11, 11<sup>1</sup>/<sub>2</sub> and 12<sup>1</sup>/<sub>2</sub> Gauge. Round-Head Nails. 2 - 3<sup>1</sup>/<sub>2</sub>" 6d - 16d Nail Range. Capacity 250 - 275.

## SFN40 H: 11<sup>1</sup>/<sub>4</sub>" L: 13" W: 4.7 lbs

A true craftsman's tool — lightweight and well-balanced with superior power.



### Benefits

- Neverlube™ Design means no tool lubrication to stain fine woods
- Adjustable depth-of-drive allows for flush drive or precision countersinking at lower air pressure
- Low recoil — more tool power reduces effort needed for each drive

### Applications

Crown Molding, Baseboard, Chair Rail, Boards in Furniture, Door and Window Casings, Cabinet Face Frames, Decoration, Wood Furniture, Hardwood Flooring, Paneling, Upholstery Trim Panels, Trim to Steel Studs

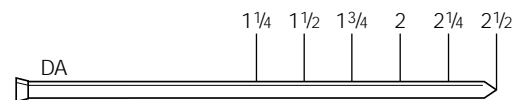

15 Gauge. Brad-Head Finishing Nails. 1<sup>1</sup>/<sub>4</sub>" - 2<sup>1</sup>/<sub>2</sub>" 4d - 8d. Smooth. Capacity 100.

**NEW:** Hardened nails also available in 1<sup>1</sup>/<sub>2</sub>" and 1<sup>3</sup>/<sub>4</sub>" for applying trim to light gauge and heavy gauge steel studs.

# Finish Tools (continued)

## SFN30 H: 9 5/8" L: 12" W: 3.6 lbs

Compact finish nailer with modular PowerPlus® design for high reliability and low maintenance.



### Benefits

- Neverlube™ Design means no tool lubrication to stain fine woods
- Adjustable depth-of-drive allows for flush drive or precision countersinking at lower air pressure
- Lightweight — 3.6 lbs makes it easy to maneuver in tight spots
- Handy belt-hooks adjust for left or right hand users to keep the tool close by

### Applications

Finishing Applications in Construction, Furniture and Cabinets, Picture Frames, Hardwood Flooring, Molding, Baseboard, Chair Rail, Paneling, Nailable Plastic Parts, Door and Window Casings, Upholstery Trim Panels, Trim to Steel Studs



15 Gauge. Brad-Head Finishing Nails. 1" - 2" 2d - 6d. Smooth. Capacity 104.

**NEW:** Hardened nails also available in 1 1/2" and 1 3/4" for applying trim to light gauge and heavy gauge steel studs.

## FinishPro 25 H: 9.9" L: 10" W: 2.7 lbs

Feature loaded with on-tool power adjustment makes this the perfect tool for any job.



### Benefits

- Increase power by 30% with a simple on-tool adjustment
- Adjustable exhaust, no tool required
- Adjustable depth-of-drive
- Neverlube™ – doesn't require oil
- Easy loading with a lock back feeder shoe

### Applications

Molding and Decorative Trim, Furniture Trim, Window Beading, Blind Pinning of Upholstered and Trim Panels, Rattan, Scribe Molding, Cabinets, Drawer and Picture Frame Assembly

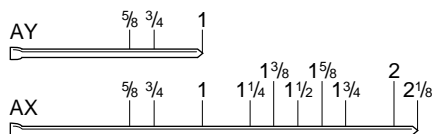

18 Gauge slight-head brads from 5/8" to 1".  
18 Gauge medium-head brads from 5/8" to 2 1/8".  
Capacity: 110.

## SLP20 H: 8 1/4" L: 9 1/2" W: 2.3 lbs

Versatile nailer drives both slight-headed and medium-headed brads with 40% more power than comparable tools.



### Benefits

- Maneuverable and at 2.3 lbs, the lightest on the market
- Neverlube™ Design means no tool lubrication to stain fine woods
- Easy to maintain and service — only two moveable O-rings for virtually trouble-free upkeep

### Applications

Molding and Decorative Trim, Furniture Trim, Window Beading, Blind Pinning of Upholstered and Trim Panels, Rattan, Scribe Molding, Cabinets, Drawers, Picture Frame Assembly

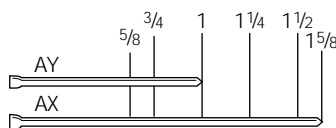

18 Gauge. Slight-Head Brads 5/8" - 1".  
18 Gauge. Medium-Head Brads 5/8" - 1 5/8".  
Capacity 110.

## SHP10 H: 5<sup>1</sup>/<sub>16</sub>" L: 8<sup>5</sup>/<sub>16</sub>" W: 2.4 lbs

Maneuverable headless pinner designed with streamlined barrel to fit in tight spaces.



### Benefits

- Well-balanced and lightweight at only 2.4 lbs
- Easy bottom loading with one-touch magazine release
- Drives the smallest to the largest headless pins for a no-mar finish

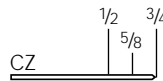

23 Gauge. Headless Pins 1/2" - 3/4".  
Smooth. Capacity 200

### Applications

Molding and Decorative Trim,  
Glazing Strips and Window  
Beading, Dowel and Joint Pinning,  
Rattan Furniture, Mirror and Picture  
Frame Assembly

## Corrugated/Clamp Tools

## SC1 H: 9<sup>1</sup>/<sub>16</sub>" L: 12<sup>1</sup>/<sub>16</sub>" W: 6.3 lbs

This unique joint fastener clamps together butt joints in hard woods.



### Benefits

- Senclamp® fasteners pull the joint together during driving for a tight, permanent fit
- Consistent drives even in hard woods

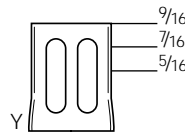

1/16" Crown. 25 Gauge. Senclamp®.  
3/16" - 9/16" Lengths. Capacity 120.

### Applications

Cabinet Door Frames, Face Frames,  
Picture and Mirror Frames, Caskets,  
Curios, Butt Joints

## SC2 H: 9<sup>3</sup>/<sub>4</sub>" L: 12<sup>1</sup>/<sub>16</sub>" W: 6.9 lbs

Corrugated fastener provides twice the strength of ordinary fasteners.



### Benefits

- Added strength for larger butt joints
- Powerful for hard and dense material

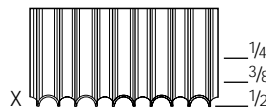

1" Crown. 25 Gauge. Sencor® corrugated fasteners.  
1/4", 3/8" and 1/2" Lengths. Capacity 106.

### Applications

Butt Joints in Cabinet and Furniture  
Frames, Door and Window Sash and  
Millwork, Truss Construction,  
Picture Frames, Wood Boxes,  
Pallet Stringer Repair

# Metal Connector Nailers

## SN60MC H: 12<sup>3</sup>/<sub>16</sub>" L: 14" W: 7.7 lbs

Designed with the PrecisePoint™ hole locator system that uses the nail point for faster, simpler hole location.



### Benefits

- Flush drive system drives nails flush with the metal connector without distortion
- Lightweight at 7.7 lbs and well-balanced for easy handling overhead, straight down or on its side
- Compact design for maneuverability in tight spots

### Applications

For Fastening Metal Connector Straps, Ties, Joist Hangers and Anchors in Framing, Trusses, Decking, Boxes and Crates

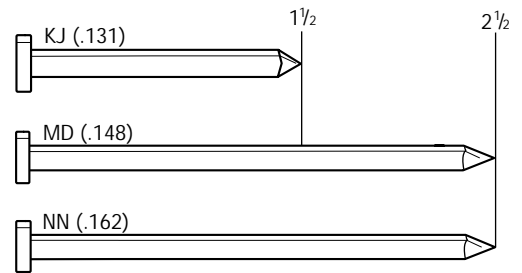

8-10 Gauge. 1/2" - 2 1/2" 4d - 8d. Full Round-Head Nails. Bright Basic and Hot Dip Galvanized Nails. Capacity 30.

## A9 Hand Nailer H: 5" W: 2.6 lbs

Compact, well-balanced palm nailer for fastening in tight spaces.



### Benefits

- Balanced 2.5 lbs weight reduces fatigue
- Operates from 80 to 125 p.s.i.g
- Depth-of-drive control for precise nail placement

### Applications

For Fastening Metal Connector Straps, Ties, Joist Hangers and Anchors or Nailing in Tight Spaces

Drives bulk nails from 6d up to 70d with optional adapters.

## A20 Hand Nailer H: 5" W: 2.6 lbs

Compact, well-balanced palm nailer for fastening in tight spaces.



### Benefits

- Balanced 2.5 lbs weight reduces fatigue
- Operates from 80 to 125 p.s.i.g
- Depth-of-drive control for precise nail placement
- Molded comfort grip
- Includes leather grip

### Applications

For Fastening Metal Connector Straps, Ties, Joist Hangers and Anchors or Nailing in Tight Spaces

Drives bulk nails from 6d up to 16d.

