



Improve your bottom line with the Signode® LB-6520 corrugated bundler

Signode's LB-6520 plastic strapping machine increases production speed, optimizes performance and maximizes efficiency to save you time and money.

Unequaled speed

The LB-6520 cycles up to 42 straps per minute, making it the fastest strapping machine in its class.

Optimum performance

Utilizing Signode's patented jam-resistant technology, the LB-6520 delivers the most reliable performance available today. The strapping head's self-lubricating, adjustment-free design also provides excellent durability and maintenance-free

operation. All-welded steel construction provides superior durability.

Maximum efficiency

To make the LB-6520 a truly operatorless machine, we've included our patented automatic cut off and refeed mechanism. If the machine detects a strap feeding problem in the chute, it automatically cuts off and ejects the strap, rethreads itself and resumes strapping without operator intervention. Productivity is further enhanced with other standard, timesaving features, including waist-high, automatic loading and single-button operation for quick, effortless strap feeding and cycling. We've also included a built-in cycle counter to facilitate preventive maintenance.

Signode® LB-6520 corrugated bundler

Designed specifically for the corrugated industry

■ Fully accessible strap path

Machine and strapping guides are easily opened, providing complete access to the strap path without using any tools.



■ Automatic loading

Two simple steps:

1. Lift the lever and insert strap into the slot.
2. Push the cycle button. The machine threads itself and is ready to go.



■ Portable operator controls

Facilitates operation from either side of the machine.



■ Automatic cut-off and refeed

Unlike other strapping machines that require an operator to clear strap jams, the Signode LB-6520 automatically ejects misfed strap, rethreads itself and continues strapping without operator intervention.

■ Single adjustable photo eye

For accurate strap placement.

■ Built-in cycle counter

Helps facilitate preventive maintenance programs.

■ Powered roller conveyor

Powered knurled steel rollers provide superior bundle traction and load stability.

■ Single compression

Adjustable up to 175 lbs.

■ 1/2-Turn dispenser cover

Faster coil changes provide greater uptime.

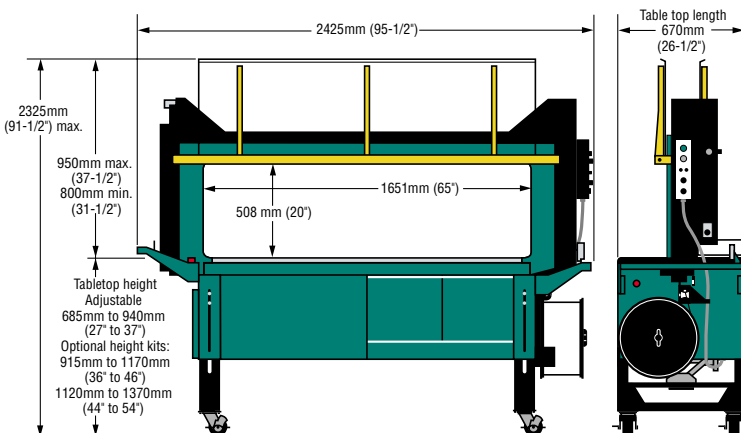

Options

- Dual compression
- Indicator light
- Variable speed conveyor
- Conveyor interlock kit
- Height adjustment kit
- Foot cycle switch
- Floor lock kit

Specifications

Maximum package size
65"W x 19.5"H

Minimum package size
6"L x 6"W x 1"H

Cycle rate

Up to 42 straps per minute. Actual production will vary depending on conveyor speed and package size.

Strap requirements

5mm or 6mm polypropylene strapping.

Tension range

Adjustable from 15 to 60 lbs.

Conveyor height

Adjustable from 27" to 36". Optional height kits: 36" to 46" or 44" to 54".

Electrical

208, 230 or 460 volts, 3 phase, 60 Hz;
575 volts, 3 phase, 60 Hz (optional)

Shipping weight

Approximately 1300 lbs.

 **SIGNODE®**

Signode Distributor Sales
180 Hastings Dr
Buffalo Grove, IL 60089-6989
800.526.1948