

Manual combination, seal-feed/Steel

Manual combination strapping tools

Combination tools function as tensioners, sealers, and often cutters as well. They save time by eliminating the handling of separate tools. But because they weigh more than such tools, they should be placed as close as possible to the position where they will be used. Seal-feed combination tools carry a stack of seals in a magazine for fast, easy loading.

Manual seal-feed

Manual seal-feed combination tools that tension, seal and cut strapping include the AH, AL, and AM series models.

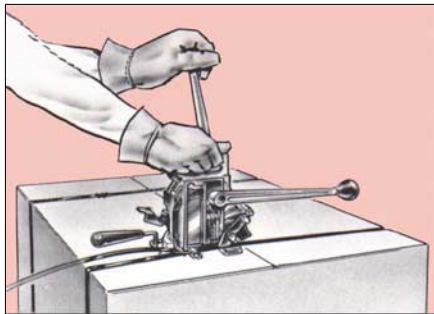

**AM-12
AM-58
AM-34**

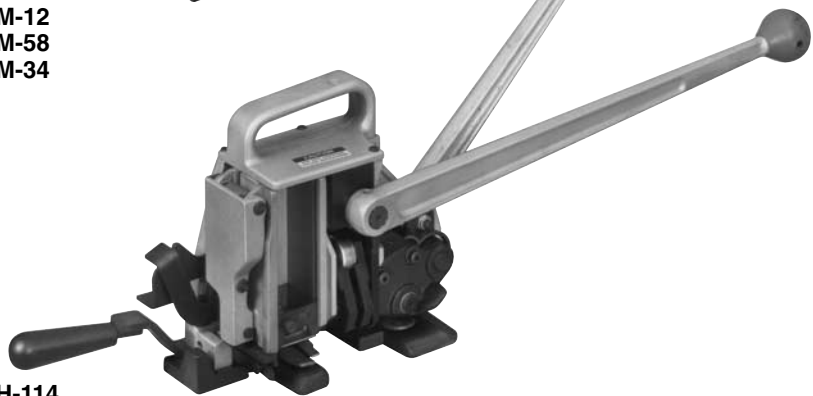

AH-114

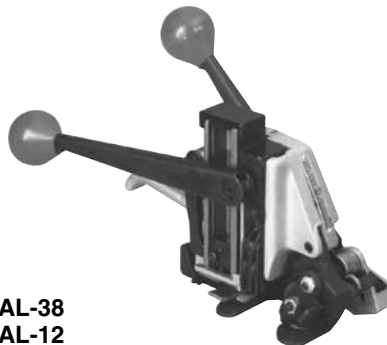

**AL-38
AL-12**

Manual seal-feed combination tool specifications

Model	Part Number	Description	Mechanical Advantage ¹	Strap Size				Strap Type	Seal Used	Joint Type	Base Length Under Strap		Weight	
				Width		Thickness					inch	mm	lbs	kg
				inch	mm	inch	mm							
AL-38	023380	Seal-Feed	15	3/8	9.5	0.015-0.017	0.38-0.43	Apex Plus	38AL	Double Notch	3-1/4	83	8	3.6
AL-12	023300		15	1/2	12.7	0.017	0.43	Apex Plus	12AL	Double Notch	3-1/4	83	8	3.6
AM-12	023230		25	1/2	12.7	0.017-0.023	0.43-0.58	Apex Plus, Magnus	12AMP	Double Notch	4-3/4	121	14	6.4
AM-58	023220		25	5/8	15.9	0.017-0.023	0.43-0.58		58/34AMP	Double Notch	4-3/4	121	14	6.4
AM-34 ²	023200		25	3/4	19.0	0.017-0.025	0.43-0.64	58/34AMP	Double Notch	4-3/4	121	14	6.4	
AH-114	015700		35	1-1/4	31.8	0.031-0.035	0.79-0.89	Magnus	114A	Double-R-Notch ³	8-3/8	213	25	11.3

1. Mechanical advantage indicates approximately how many times the force applied to the handle is multiplied to provide tensioning.

2. A conversion kit is available to accommodate 0.031 strapping (Part No. 306815).

3. Seal notches reverse (R) to prevent indentation on fragile or highly polished surfaces.

Steel/Manual combination, sealless

3610 W. Lake Ave. • Glenview, IL 60025
1-800-323-2464

Manual sealless

The SCM sealless combination tool requires no metal seals, saving time and money. Production interruptions for reloading are eliminated, along with the purchasing, inventorying and loading of seals.



Three key sealless joint

SCM-12
SCM-58
SCM-34



Manual sealless combination tool specifications

Model	Part Number	Description	Strap Size				Strap Type	Sealless Joint Type	Mechanical Advantage*	Base Length Under Strap		Weight	
			Width		Thickness					inch	mm	lbs	kg
			inch	mm	inch	mm							
SCM-12	424350	Sealless	1/2	12.7	0.017-0.023	0.43-0.58	Apex Plus, Magnus	17	4-3/8	111	8.4	3.8	
SCM-58	424358		5/8	15.9	0.017-0.023	0.43-0.58							
SCM-34	424334		3/4	19.0	0.017-0.025	0.43-0.64							

* Mechanical advantage indicates approximately how many times the force applied to the handle is multiplied to provide tensioning.