

Strapping Dispensers/Steel



DF-7A
Inexpensive model for mill wound coils. General use.



DF-15
For typical shipping room. Easily loaded with mill wound coils.



DF-10RW
Accepts mill wound or ribbon wound coils 3/4" and 1-1/4" in width.



DO-3A
Overhead dispenser for mill wound coils. Wall (WB) and ceiling (CB-9) mounting brackets available.

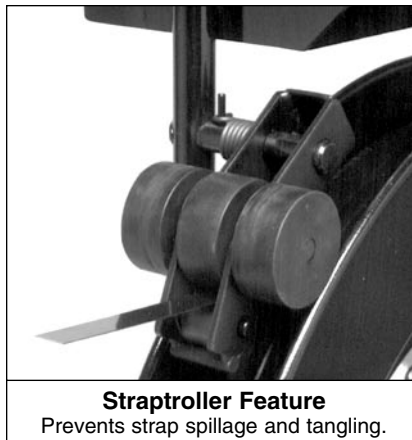

Straptroller Feature
Prevents strap spillage and tangling.



DF-23
Fits almost anywhere. Pays off from the inside of the coil. Mobile with optional DM-23 cart. Cover required for strap over 0.023" (0.58 mm). Cover sold separately.



DM-23
Makes the DF-23 mobile.



DP-1-23B
Electric-powered DF-23 for power equipment only. Cover required for strap over 0.023" (0.58 mm). Cover sold separately.

Strapping dispenser specifications

Strap Dispenser Model	Part Number	Strap Size		Coil winding		Feeds from		Strap-troller Feature	Portable	Tool tray	Dimensions						Dispenser Weight	
				Mill	Ribbon	Outside Vert. coil	Inside Horiz. coil				Height		Width		Length			
		inch	mm			inch	mm				inch	mm	inch	mm	lb	kg		
DF-7A	059999	3/8-3/4	9.5-19.0	•		•			•	•	28	711	13-1/2	343	35	889	63	28
DF-15*	273725	3/8-3/4	9.5-19.0	•		•		•	•	•	37-3/4	959	25	635	16	406	54.5	24.7
DF-10RW	020420	3/4 or 1-1/4	19.0-31.8	•	•	•		•	•	•	41	1 041	18-1/2	470	28	711	94	43
DO-3A	002870	3/8-3/4	9.5-19.0	•		•		•			31	787	6-3/4	171	27-3/4	705	41	18
DF-23	024200	3/8-3/4	9.5-19.0	•			•				8	200	24-1/2	622	24-1/2	622	35	16
DP-1-23B	002393	3/8-3/4	9.5-19.0	•			•				8	200	24-1/2	622	35-1/2	902	88	40

*Dispenser can also be used with plastic strapping.

Accessories

Steel/Strapping Dispensers

3610 W. Lake Ave. • Glenview IL 60025
1-800-323-2464

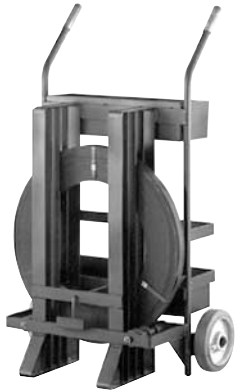

DTR-3
Heavy-duty carloading. Rubber tires for easy mobility. Holds one coil 3/4", two coils 1-1/4", and one coil 2" strapping.



DT-1-10RW
Heavy-duty dispenser. Ideal for outdoor use in rough terrain.



DH-1-34, DH-1-114, DH-1-2
For use with heavy-duty strapping.



DA-34-114
Heavy-duty dispenser. Pays off from inside of coil.



DM-1
Mobile dispenser with built-in filter-regulator-lubricator. Holds spare coil.

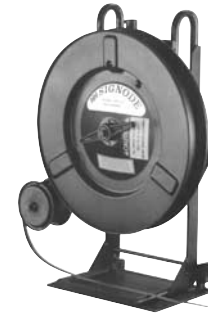

DF-1-12
For power equipment only. Dancer arm and brake.

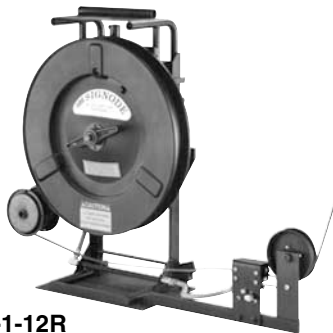

DP-1-12R
Pneumatic reversing dispenser. Generally for power strapping machines with large chute systems.

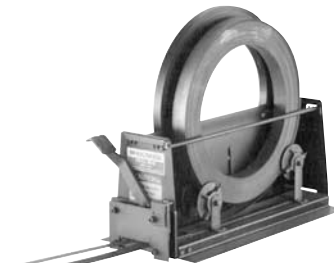

DC-1A
Built-in strap cutter for pre-cutting. Holds any two ribbon wound coils.

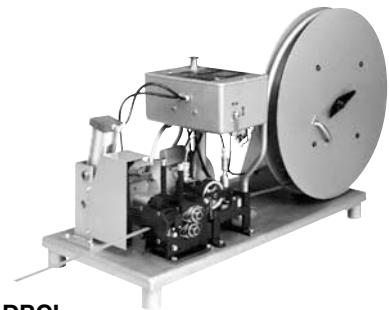

DPCL
Dispenser cuts strap automatically up to 100 ft. in length.

Strapping dispenser specifications

Strap Dispenser Model	Part Number	Strap Size		Coil winding		Feeds from		Strap-troller Feature	Portable	Tool tray	Dimensions						Dispenser Weight	
				Mill	Ribbon	Outside Vert. coil	Inside Horiz. coil				Height		Width		Length		lb	kg
		inch	mm	inch	mm	inch	mm				inch	mm	inch	mm	inch	mm	lb	kg
DTR-3	164520	3/4-2	19.0-50.8		•	•			•	•	46-1/2	1 181	15-1/4	387	27-1/2	699	110	50
DT-1-10RW	011442	5/8-1-1/4	15.9-31.8	•	•	•		•	•	•	42	1 067	22	559	34	864	125	57
DH-1-34	047538	3/4	19.0		•	•					29-3/4	756	6-3/4	171	22-1/4	565	46	21
DH-1-114	047537	1-1/4	31.8		•	•					29-3/4	756	7-1/4	184	22-1/4	565	46	21
DH-1-2	047539	2	50.8		•	•					29-3/4	756	8	203	22-1/4	565	46	21
DA-34-114	020400	3/4 or 1-1/4	19.0-31.8		•		•				25-1/4	641	27-1/2	699	31	787	131	59
DM-1	020750	3/4 or 1-1/4	19.0-31.8		•		•		•	•	33-1/4	845	30-1/2	775	43-1/2	1 105	190	86
DF-1-12	031317	3/8-3/4	9.5-19.0	•		•					32	813	10	254	24-1/2	622	95	43
DP-1-12R	040900	3/8-3/4	9.5-19.0	•		•					36-3/4	933	12-3/8	314	47-1/4	1 200	170	77
DC-1A	005720	3/4-2	19.0-50.8		•	•					29*	737	15	381	32-1/2	826	97	44
DPCL	083001	3/8-2	9.5-50.8	•	•	•					36	914	21	533	52	1 321	450	204

* With coil.